



Marathon[®] CP-20 Cryopump

Operating Manual

Sumitomo (SHI) Cryogenics of America, Inc.
1833 Vultee Street
Allentown, PA 18103-4783
U.S.A.

TABLE OF CONTENTS

	<u>Page</u>
SAFETY	1
SERVICE	3
INTRODUCTION	5
Cryopumps.....	5
PRINCIPLES OF OPERATION	7
DESCRIPTION	9
Cryopump Components.....	10
SPECIFICATIONS	11
Cold Head	11
Pumping Speeds	11
Throughput.....	11
Capacity	11
Crossover Rating.....	11
Cooldown Time	11
Weight.....	11
Mounting Flange.....	11
Connections	11
Gas Line Couplings	11
Cold Head Cable Receptacle	11
Standard Single Silicon Diode Temperature Sensor and Optional Dual Temperature Sensor (for MCC)	11
Standard Single Temperature Sensor Connector	12
Optional Dual Temperature Sensor Connector (for MCC).....	12
Alternate Single Silicon Diode Temperature Sensor	12
Compressor.....	12
Refrigerant Quality.....	12
Adapter Fittings (Optional Accessories).....	13
Environmental Requirements	13
Maintenance Interval	13
Supplier Name and Address.....	13
INSTALLATION	15
Introduction	15
Unpacking, Inspection and Pressure Check.....	15
Cryopump Lifting Instructions.....	17
Compressor Position.....	18
Compressor Checkout	18
Remove the Existing Pumping System	19
Temperature Sensor Cable Assembly (Optional Accessory)	20
Install the Cryopump	20
Install the Gas Lines	21
Install the Cold Head Cable.....	23
Connect the Purge Gas, Vacuum and Vent Lines	23
Remote On/Off Cable (Optional Accessory).....	25

||

TABLE OF CONTENTS
(continued)

	<u>Page</u>
ACCESSORIES	27
Installation	27
Pumpout/Nitrogen Purge Adapter	28
Silicon Diode or Hydrogen Vapor Bulb Temperature Sensor	28
OPERATION	29
Prestart Check.....	29
Startup.....	30
Regeneration.....	32
Regeneration: Warm-Up Phase.....	32
Regeneration: Purge Phase	33
Regeneration: Evacuation Phase	34
Regeneration: Cooldown Phase	34
Regeneration: Crossover.....	35
Vacuum Baking	36
Restarting after a Power Failure	36
System Shutdown	37
MAINTENANCE	39
Cryopump Handling and Shipping	39
Compressor Adsorber Replacement.....	41
Remove the Cryopump from the Vacuum Chamber	41
Disconnect the Gas Lines.....	42
Cryopanel Maintenance.....	43
Disassemble and Clean the Cryopanel.....	44
Reassemble the Cryopanel.....	44
Clean the Relief Valve	45
Clean the Relief Valve's Filter Screen	45
Rupture Disc.....	45
Standard Silicon Diode	46
Functional Check.....	46
Optional Dual Silicon Diode used with a Marathon [®] Cryopump Controller (MCC).....	46
Functional Check of the Dual Silicon Diodes	47
Hydrogen Vapor Bulb	47
Cold Head Maintenance	48
Cold Head Removal from the Cryopump	48
Cold Head Installation into the Cryopump.....	48
Charging and Venting.....	48
Charging Procedure	49
Venting Procedure to Adjust the Equalization Pressure.....	49
Gas Cleanup	49
Gas Cleanup of the Gas Lines.....	49
Gas Cleanup of the Cold Head	50
Gas Cleanup of the Compressor	51
Leak Check the Refrigeration System	51
Leak Repair.....	53

TABLE OF CONTENTS
(continued)

	<u>Page</u>
TROUBLESHOOTING	55
Troubleshooting Guide	55
PARTS	63
Ordering	63
Parts Identification and Numbers.....	63

ILLUSTRATIONS LIST

Figure 1 Typical Cryopump System.....	6
Figure 2 Equilibrium Vapor Pressure vs. Temperature	7
Figure 3 Parts Identification and Stages of Freezing during Cryopumping.....	9
Figure 4 Typical Adapter Fitting.....	13
Figure 5 Restricted Areas When Lifting Cryopump.....	17
Figure 6 Lifting the Cryopump with Commercial Lift Equipment.....	18
Figure 7 Prepare Sensor Cable	20
Figure 8 Cryopump Mounting	21
Figure 9 Attach Identification Label	22
Figure 10 Connect a Gas Line to Compressor or Cryopump	23
Figure 11a Relief Valve Vent Connection Detail	25
Figure 11b Vent Adapter (Optional).....	25
Figure 12 Warm Up and Purge the Cryopump.....	33
Figure 13 Evacuate the Cryopump.....	34
Figure 14 Cryopump Crossover.....	35
Figure 15 Break the Gas Line Connection from the Cold Head	42
Figure 16 Disconnect the Gas Line from the Cold Head	42
Figure 17 Check the Silicon Diode	46
Figure 18 Check the Dual Silicon Diodes	47
Figure 19 Possible Points of Gas Leaks	52

SJM P/N 267625A

(This page is intentionally blank.)

SAFETY

GENERAL

SCAI equipment is designed to operate safely when the installation, operation and servicing are performed in accordance with the instructions in this technical manual. Consult the nearest SCAI Service Center with any questions you may have concerning the operation or maintenance of this equipment. For Service Center locations, see the Service section, which follows.

SPECIAL NOTICES

Three types of special notices, **WARNING**, **CAUTIONS** and **NOTES** are used in this technical manual.



WARNINGS call attention to actions or conditions that can result in serious injury or death.



CAUTIONS call attention to actions or conditions that can result in damage to the equipment or in abnormal performance.

NOTE

NOTES give important, additional information, explanations or recommendations related to the procedure or discussion presented.

WARNINGS and **CAUTIONS** appear in rectangles in the text where they are applicable.

Before installing and operating this equipment, be sure to read the Safety section in the General Technical Manual for Cryopump Systems, 261802A

Pay particular attention to the Section SPECIAL PROCEDURES for CRYOPUMPING OXYGEN or OZONE.



AVOID INJURY. Failure to operate this equipment in the manner specified in this manual may create a hazardous condition resulting in serious injury to the operators and/or damage to the equipment.

NOTE

Parallel lines (||) in the right margins identify changes from the previous revision.

(This page is intentionally blank.)

SERVICE

HEADQUARTERS

Sumitomo (SHI) Cryogenics of America, Inc.
1833 Vultee Street
Allentown, PA 18103-4783

Sales and Parts

TEL: (800) 525-3072
or
(610) 791-6700
FAX: (610) 791-0440

Service

TEL: (800) 525-3071
or
TEL: (610) 791-6750

SERVICE CENTERS

Eastern U.S.A.

Sumitomo (SHI) Cryogenics of America, Inc.
1833 Vultee Street
Allentown, PA 18103-4783

TEL: (800) 525-3071
or
(610) 791-6750
FAX: (610) 791-3904

Western U.S.A.

Sumitomo (SHI) Cryogenics of America, Inc.
1800 Wyatt Dr.
Suite 13
Santa Clara, CA 95054

TEL: (408) 736-4406/4407
FAX: (408) 736-7325

Europe

Sumitomo (SHI) Cryogenics of Europe, Ltd.
3 Hamilton Close
Houndmills Industrial Estate
Basingstoke
Hampshire RG21 6YT
United Kingdom

TEL: +44 1256 853333
FAX: +44 1256 471507

Sumitomo (SHI) Cryogenics of Europe, GmbH
Daimlerweg 5a
D-64293 Darmstadt
Germany

TEL: +49 6151 860 610
FAX: +49 6151 800 252

Asia

Sumitomo Heavy Industries, Ltd.
Service Section
Cryogenics Division
2-1-1 Yato-Cho Nishitokyo-City
Tokyo 188-8585
Japan

TEL: +81 424 68 4265
FAX: +81 424 68 4462

Sumitomo (SHI) Cryogenics Korea, Co., Ltd.
3F, 280-3, Saneop-ro
155beon-gil, Gweonseon-Gu
Suwon-Si, Gyeonggi-Do
South Korea

TEL: +82 31 278 3050
FAX: +82 31 278 3053

Sumitomo Heavy Industries (Shanghai)
Management, Ltd.
Room 107-110, Building 5
No. 100, Zixiu Road
Shanghai 201103
People's Republic of China

TEL: +86 21-6070-5200
FAX: +86 21-6070-5086

Sumitomo (SHI) Cryogenics Taiwan Co., Ltd.
4th Floor, No.3
Lane 216, Gongyuan Rd.
Hsinchu City 300
Taiwan ROC

Phone: +886 3 561 2557/2101
Fax: +886 3 562 3400

(This page is intentionally blank.)

INTRODUCTION

Cryopumps

SCAI Cryopumps produce clean, fast vacuum for high-vacuum applications. The cryopump does not contribute any contamination to the vacuum chamber because it functions by capturing gases, and no moving parts or lubricants are exposed to the vacuum.

Figure 1 shows the major components of typical cryopump systems:

- helium compressor
- cryopump(s)
- gas lines
- cold head cable(s)
- optional gas manifold for connecting multiple cryopumps to the compressor.

The Marathon[®] CP-20 Cryopump uses a model CH-210 Cold Head. Both are designed to metric standards.

The information in this manual pertains only to the Marathon[®] CP-20 Cryopump System.

Pressures are stated as gauge, not absolute. Psig is pounds per square inch gauge and kPa is Kilopascals gauge.

$$\text{kPa} = 6.895 \text{ Psig}$$

Symbols on the equipment and descriptions:

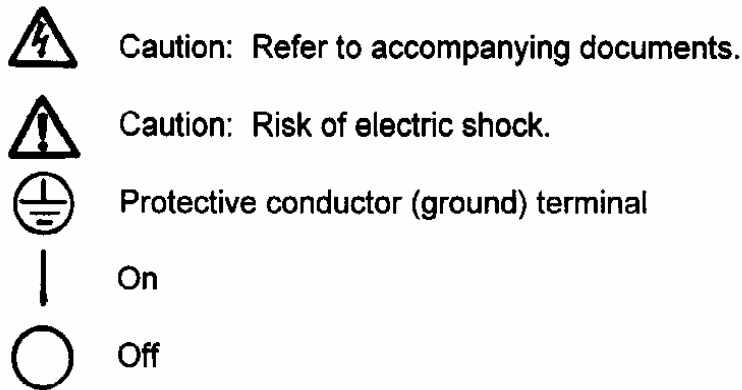

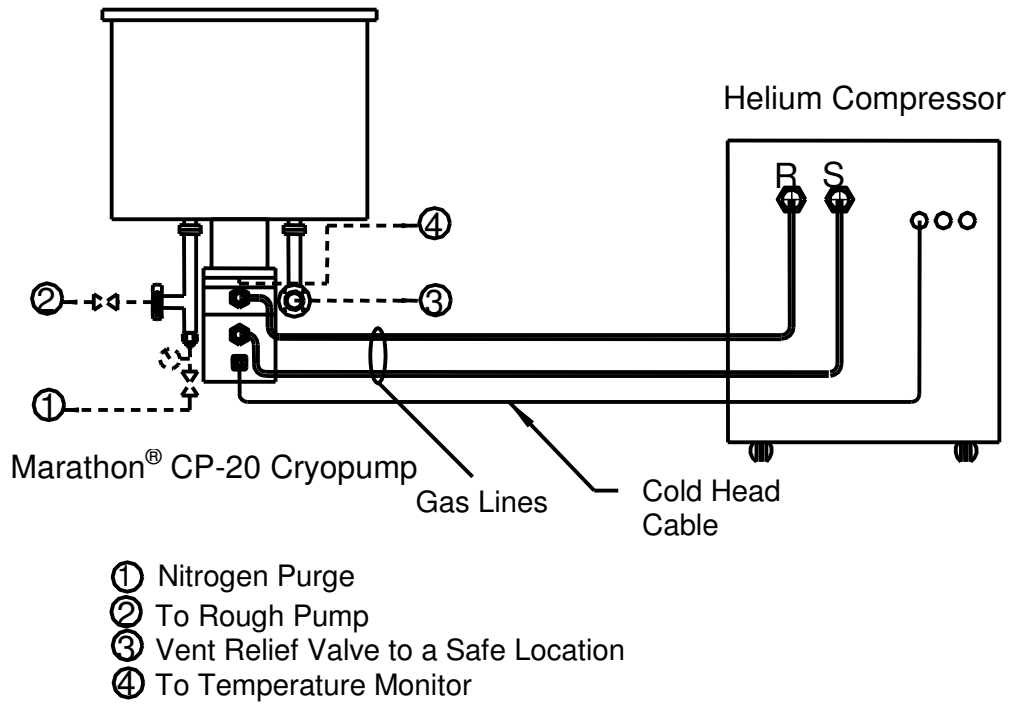

Figure 1 Typical Cryopump System

PRINCIPLES OF OPERATION

A cryopump creates a vacuum by capturing gases from the vacuum chamber. The pump does this by solidifying gases onto cold surfaces. See Figure 3.

Typical cryopumps have a cryogenic refrigerator (cold head) that produces refrigeration at two temperature levels and cools two, extended-surface cryopanel onto which the gases can freeze. The first stage of the cold head, operating in the range of 50 to 75 K, cools the outer cryopanel that shields the colder, second-stage cryopanel against radiant heat and cools the louver across the inlet of the pump. Water vapor freezes out when it hits the louver.

The second stage of the cold head, which operates between 10 and 20 K, cools the inner cryopanel that freezes out nitrogen, oxygen and argon after they pass through the louver. On the inside of the cold cryopanel, charcoal adsorbs gases that will not freeze at second-stage temperatures.

A cryopump can reduce the pressure in a vacuum chamber to very low levels. Figure 2 shows the relationship between the equilibrium vapor pressures and temperatures of frozen gases. Because the equilibrium vapor pressures for neon, hydrogen and helium are too high at 20 K to freeze these gases onto a bare surface, charcoal is used to adsorb them.

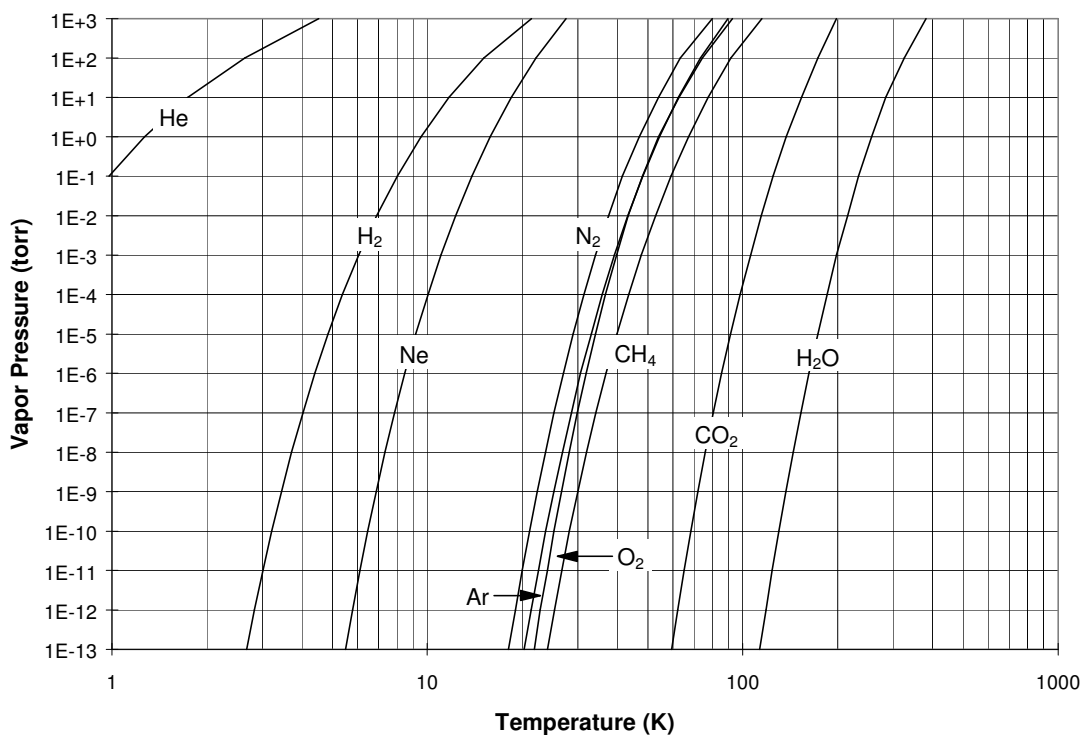

Figure 2 Equilibrium Vapor Pressure vs. Temperature

(This page is intentionally blank.)

DESCRIPTION

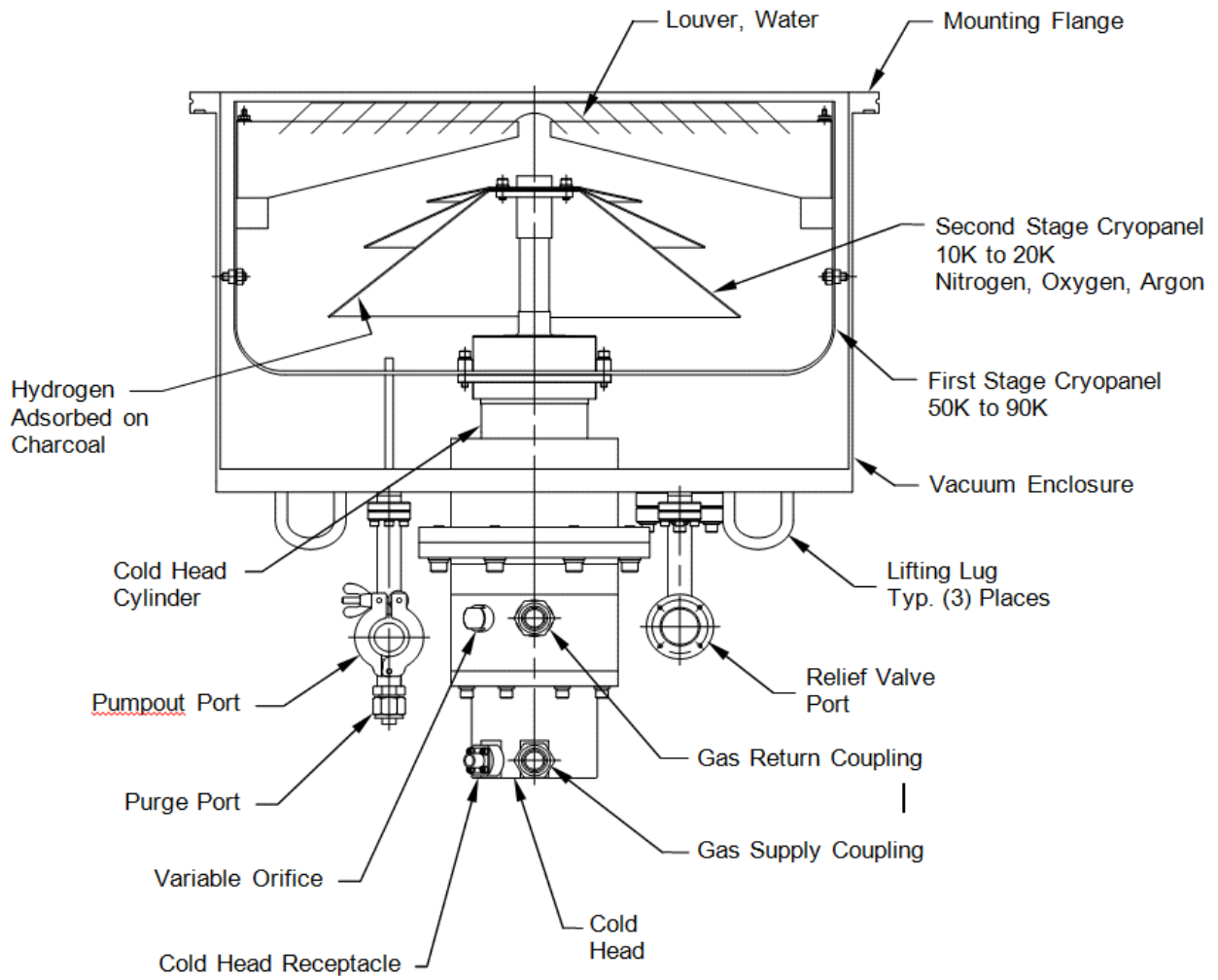

Figure 3 Parts Identification and Stages of Freezing During Cryopumping

Cryopump Components (See Figure 3)

Cold Head: Provides the refrigeration necessary to cool the cryopanel.

Cold Head Cylinder: This part of the cold head includes the heat station flanges onto which the cryopanel is mounted.

First-Stage Cryopanel: Shields the second-stage cryopanel from radiant heat:

Louver: A series of concentric rings that captures water vapor and shields the second-stage panel from radiant heat.

Mounting Flange: 20" ANSI, mates the cryopump assembly to the operator's vacuum chamber.

Nitrogen Purge Port: Nitrogen supply connection for regeneration purge and hazardous gas dilution.

Pressure Relief Devices: Two types of pressure relief devices, a pressure relief valve or a rupture disc, are available.

A pressure-relief valve is attached to the vacuum enclosure. The valve is designed to open and vent gases if the pressure rises to 7 kPa (1 psig).

A rupture disc is used in ultra-high vacuum (UHV) systems instead of a relief valve. The disc will burst if the internal pressure of the cryopump exceeds 124 kPa (18 psig).

Pumpout Port: Allows the operator to connect a roughing pump to the cryopump for evacuating the cryopump vacuum enclosure. Close the vacuum valve after the initial evacuation.

Second-Stage Cryopanel: Captures nitrogen, oxygen and argon by solidification on copper surfaces and captures hydrogen and helium by adsorption in charcoal.

Temperature Sensors: Two types of sensors, encapsulated silicon diode or hydrogen vapor bulb, are available to measure second-stage temperature. For a cryopump connected to a Marathon[®] Cryopump Controller, an alternate dual diode is furnished to measure first-stage and second-stage temperatures.

The silicon diode is encapsulated in a cartridge and the diode wires are covered with tubing to prevent the diode from becoming an ignition source. Sensor lead wires exit the vacuum enclosure through a hermetically-sealed connector so the sensor can be monitored remotely.

The vapor-bulb sensor is filled with hydrogen gas. The pressure gauge, calibrated in degrees K, monitors the vapor pressure of the gas. The gauge is mounted locally on the vacuum enclosure. The sensor has a useful temperature range indication of 14 K to 24 K.

Vacuum Enclosure: Forms the vacuum boundary around the cryopanel.

Cold Head SCAI model CH-210.

Pumping Speeds

Air	9,700 liters/second
Water	29,100 liters/second
Argon	8,300 liters/second
Nitrogen	9,900 liters/second
Hydrogen	14,000 liters/second

Throughput Argon, 11.3 torr-liters/sec or 900 sccm

Capacity Argon, 6,000 std. liters
Hydrogen, 33 std. liters

Crossover Rating 400 torr-liters (nitrogen)

Cooldown Time 190 minutes to 20 K

Weight 76 kg (168 lbs.)

Mounting Flange ISO 500, claw type

Connections Pumpout Port: ISO NW25
Nitrogen Purge Gas Port: Parker UltraSeal, size 6
Relief Valve Vent Connection: See Figure 9b
Temperature Sensor Port: 4 pin electrical receptacle for single diode,
10 pin electrical receptacle for dual diode.

Gas Line Couplings

Supply and return helium gas connections are size 8, male (8M) Aeroquip self-sealing couplings.

Cold Head Cable Receptacle

The receptacle is a 4 pin, 8 shell Detronics connector.

Standard Single Silicon Diode Temperature Sensor and Optional Dual Temperature Sensor (for MCC)

With a 10 μ A DC current excitation, the encapsulated silicon diodes supplied with the cryopump have the following voltage/temperature characteristics:

<u>Temperature (K)</u>	<u>Output (Volts)</u>	<u>Temperature (K)</u>	<u>Output (Volts)</u>
8	1.4723	24	1.1146
10	1.3956	40	1.0855
12	1.3385	60	1.0530
14	1.2918	80	1.0190
16	1.2517	100	0.9832
18	1.2151	160	0.8655
20	1.1759	200	0.7806
22	1.1293	300	0.5567

Standard Single Temperature Sensor Connector

The receptacle is a 4 pin, bayonet connector, shell size 10. See Figure 14 for terminal polarities.

Accuracy: ± 2.0 K for 4 K to 25 K, ± 5.0 K for 25 K to 450 K

Optional Dual Temperature Sensor Connector (for MCC)

The receptacle is a 10 pin, bayonet connector, shell size 12. See Figure 17 for terminal polarities.

Accuracy: ± 1.0 K for 2 K to 25 K, ± 2.0 K for 25 K to 450 K

Alternate Single Silicon Diode Temperature Sensor

With a 10 μ A DC current excitation, this alternate encapsulated silicon diode supplied with the cryopump has the following voltage/temperature characteristics:

<u>Temperature (K)</u>	<u>Output (Volts)</u>	<u>Temperature (K)</u>	<u>Output (Volts)</u>
10	1.392	24	1.099
12	1.355	40	1.061
14	1.299	60	1.007
16	1.226	80	0.952
18	1.114	100	0.898
20	1.110	200	0.626
22	1.104	300	0.352

Accuracy: ± 2.0 K for 16 K to 26 K, ± 4.0 K for 26 K to 120 K, ± 5.0 K for 120 K to 300 K

Compressor

For Electrical Characteristics, Cooling Requirements, Helium Gas Pressures and other Compressor characteristics, refer to the Compressor technical manual.

Refrigerant Quality

Refrigerant is 99.995% pure helium gas with a dew point less than -50° C (-58° F) at 2070 kPa (300 psig).

CAUTION
PRESERVE YOUR WARRANTY. Specifications require the use of 99.995% pure helium gas. Using a lesser quality of helium can damage the system and void the warranty.

Adapter Fittings (Optional Accessories)

The following adapter fittings, required for servicing the Marathon[®] CP-20 Cryopump System, are available as accessories. Figure 4 shows a typical, valved adapter fitting.

<u>Item</u>	<u>Quantity</u>	<u>Descriptions</u>	<u>Part Number</u>
1	2	Adapter Fitting, 8F ⁽¹⁾ with valve	255919B2
2	1	Adapter Fitting, 8M with valve	SK8217A2

⁽¹⁾Denotes size 8, female Aeroquip coupling.

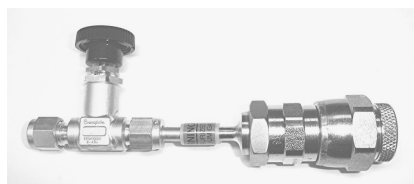

Figure 4 Typical Adapter Fitting

Environmental Requirements

	<u>Operating Environment</u>	<u>Storage</u>
Ambient Temperature	4° C to 40° C (40° F to 104° F)	-23° C to 65° C (-10° F to 149° F)
Relative Humidity	30% to 70%	10% to 90%
Atmospheric Pressure	52 kPa to 110 kPa (7.5 psia to 16.0 psia)	52 kPa to 110 kPa (7.5 psia to 16.0 psia)
Magnetic Field Limits	≤ 150 gauss	

Maintenance Interval

Cold head valve and displacer seals: 13,000 operating hours (18 months)

Supplier Name and Address

Sumitomo (SHI) Cryogenics of America, Inc.
1833 Vultee Street
Allentown, PA 18103-4783
U.S.A.

(610) 791-6700.

Regulatory Compliance

**Declaration of Conformity
Marathon® CP-20 Cryopump**

Manufacturer's Name	Sumitomo (SHI) Cryogenics of America, Inc.
Manufacturer's Address	1833 Vultee Street Allentown, PA 18103 U.S.A.
Authorized Representative's Name	Sumitomo (SHI) Cryogenics of Europe, Ltd.
Authorized Representative's Address	3 Hamilton Close Houndmills Industrial Estate Basingstoke Hampshire RG21 6YT United Kingdom
Type of Equipment	Cryogenic Refrigeration Systems

Application of Council Directives 2006/42/EC and 2004/108/EC



I, the undersigned, hereby declare that the equipment specified above conforms to the above Directives.

By: 
Robert Deobil
President, SCAI

INSTALLATION

Introduction

Install the Compressor, the Marathon[®] CP-20 Cryopump and the Gas Lines according to the following procedures.

To prevent contaminating the components or the system, it is important to follow the procedures in this manual step by step.

NOTE

Do not begin to install the components if 99.995% pure helium gas is not available. See Refrigerant Quality in Specifications.

Unpacking, Inspection and Pressure Check

CAUTION

DO NOT TIP THE COMPRESSOR greater than 5 degrees to avoid flowing oil into unwanted places and causing a nuisance shutdown.

CAUTION

AVOID CONTAMINATION. When handling any vacuum surfaces, wear clean, lint-free gloves. If the surfaces of the cryopanel become fingerprinted during unpacking or handling, clean them with a solvent recommended for oil and grease removal in high-vacuum service.

CAUTION

PREVENT EQUIPMENT DAMAGE. Do not use solvent on painted surfaces.

1. Upon delivery, inspect all shipping containers for damage.
 - 1.1 If there is any evidence of external damage to any of the containers, be sure the carrier's driver sees the damage. Note it on the shipping documents and have the driver acknowledge it by his initials on the delivery receipt.
 - 1.2 Remove all components from their shipping containers and inspect them for damage. If there was external damage to the compressor, remove its covers and check for internal damage. Notify the carrier immediately and take photographs of the damage to document your claim to the carrier. Keep the damaged shipping container.
 - 1.3 If there was external damage to any of the other shipping containers, remove the contents and inspect all items for damage. Notify the carrier immediately and take photographs of the damage to document your claim to the carrier. Keep the damaged shipping container.

NOTE

Retain the shipping containers if reusable for returning the cryopump to the factory if reconditioning is required. If internal damage is suspected, retain the shipping container for proof to the carrier.

2. Inspect the following:

- 2.1** Check the Tip-N-Tell Sensor mounted on the compressor. (Some compressors also have a Tip-N-Tell mounted on the outside of the shipping container.) If the Tip-N-Tell Sensor shows no mishandling and there is no apparent physical damage, proceed to the sections Compressor Position and Compressor Checkout.

If the Tip-N-Tell sensor indicates mishandling (arrow point is blue), read the equalization pressure. Proceed to either Step **2.2** or **2.3**.

- 2.2** The equalization pressure is within the specifications. Refer to the Compressor manual.

 **WARNING**

ELECTRIC SHOCK. All electrical supply equipment must meet applicable codes and be installed by qualified personnel.

 **WARNING**

ELECTRIC SHOCK. Permit only qualified electrical technicians to open electrical enclosures, to perform electrical checks or to perform tests with the power supply connected and wiring exposed. Failure to observe this warning can result in serious injury or death.

CAUTION

AVOID CONTAMINATION. When checking the compressor for shipping damage, do not connect gas lines and cryopump. The components may become contaminated with compressor oil.

Connect power and water to the compressor. See the next sections Compressor Positioning and Compressor Checkout. Test run the compressor for two (2) hours minimum. If there are no problems during this time, stop the compressor and proceed to assemble the system.

If the compressor shuts down during the two (2) hour test, contact the nearest SCAI Service Center.

- 2.3** If the equalization pressure is outside the specified range or there is physical damage to the compressor housing or the compressor has been on its side or upside down for an extended period of time (more than one hour), contact the nearest SCAI Service Center.

If the compressor has been momentarily tipped (less than one hour) and the equalization pressure is with specifications, allow it to stand upright for two hours before running the two-hour test in Step **2.2**.

- 3.** Remove the plastic wrapper from the cryopump.
4. Remove the cover from the mounting flange.

5. Inspect the cryopump. If it is damaged, contact the nearest SCAI Service Center and notify the delivering carrier.
6. All components in the gas system were cleaned and charged with helium gas at the factory. Allow the compressor to reach room temperature. Read the pressure gauge(s) on the compressor before connecting it into the system to determine if leaks have occurred which may require leak checking, charging or gas cleanup.

Cryopump Lifting Instructions

CAUTION

PREVENT EQUIPMENT DAMAGE. Always remove heater blanket before attempting to lift or move the cryopump.

CAUTION

PREVENT EQUIPMENT DAMAGE. DO NOT lift or move the cryopump using the purge or rough valve and their piping, the relief valve assembly, the temperature sensor connector, or the gas line connectors. See Figure 5.

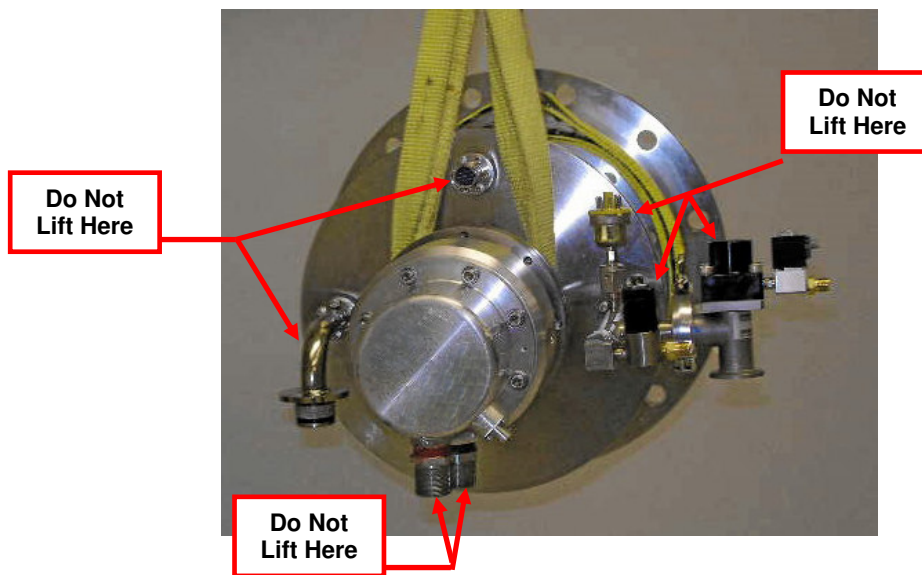

Figure 5 Restricted Areas When Lifting Cryopump

1. Using properly rated commercial equipment, lift or move the cryopump as shown in Figure 6. Be sure the cryopump is held in a balanced and stable position. Follow all applicable safety procedures for overhead material transport.

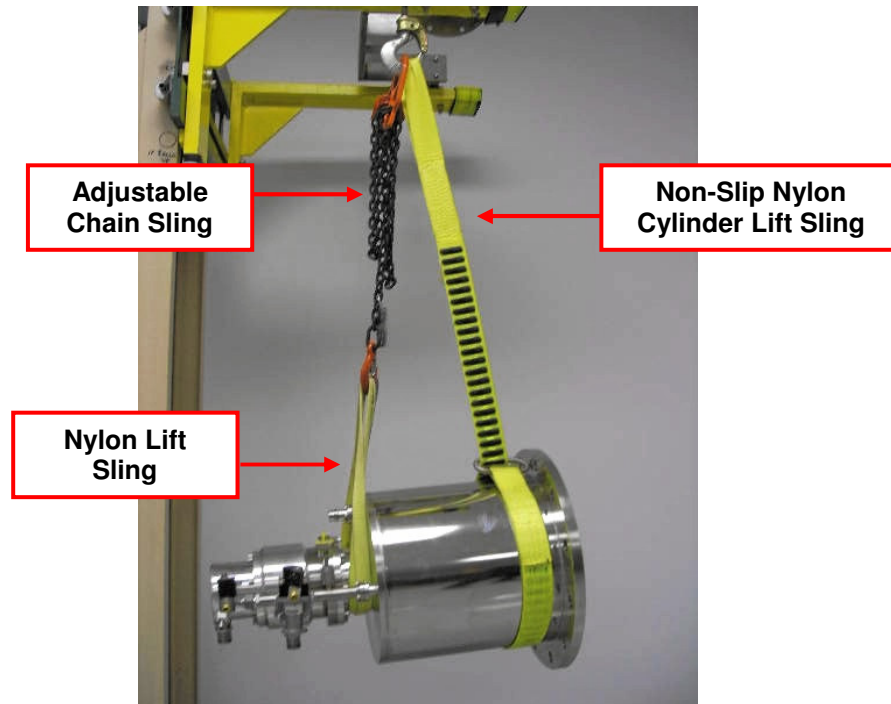

Figure 6 Lifting the Cryopump with Commercial Lift Equipment

Compressor Position

Place the compressor in a location that is protected from the elements and where the ambient temperature will always be within the range specified in the Cooling Requirements section of the Compressor manual.

 WARNING
<p>AVOID EQUIPMENT DAMAGE. Always thoroughly drain the coolant from the cooling circuit if the compressor is to be shipped or stored.</p>

The compressor must be installed base down, within 5 degrees of level, and preferably at a height convenient for making connections and reading the gauges. Be sure the compressor cannot inadvertently roll from its location, particularly if it is elevated.

Allow at least 610-mm (24") clearance from the front, rear and from both sides of the compressor for maintenance.

Compressor Checkout

The compressor should be operated before being connected to the system.

1. Use plastic tubing, nuts and ferrules from the compressor installation kit to connect coolant supply and return lines to the compression water fittings on the compressor. Connect the supply line to the supply valve furnished and installed by customer. Turn on the coolant and check lines for leaks. Tighten fittings if necessary. See Specifications in the Compressor manual for cooling requirements.

2. Be sure the power switch on the compressor is off. Plug the power cord into customer's electrical receptacle. Switch on the power to the compressor. Check that the circuit breaker is closed.
3. Press the power switch on the compressor. Power switch indicator will light and the compressor will start. The water solenoid valve (in some compressor models) will open. Check water lines for leaks. Tighten the fittings if necessary.

NOTE

An internal by-pass valve will open to prevent overloading the motor when the system gas lines are not connected to the compressor.

CAUTION

PREVENT EQUIPMENT DAMAGE. If the compressor starts but runs roughly and the supply pressure does not increase, turn it off immediately. This is an indication that the power supply leads are connected in the wrong phase sequence and the compressor is operating in the reverse direction. The compressor's circuit breaker may also trip. Disconnect the power to the compressor. Interchange any two incoming power leads (except ground) at the compressor's power cord plug or at the customer's disconnect switch. Reconnect the power and restart the compressor.

4. When the pressures stabilize, read the supply pressure gauge. The pressure should match the operating supply pressure in the Specifications section of the Compressor manual.
5. Run the compressor for 10 minutes, then stop.

This completes the checkout of the compressor.

Remove the Existing Pumping System

CAUTION

AVOID CONTAMINATION. If the cryopump is replacing an oil-diffusion pump, remove all oil residues from the gate valve.

If the Marathon[®] CP-20 Cryopump is replacing an oil-diffusion pump, the oil-diffusion pump must be removed and the remaining equipment must be cleaned before installation of the cryopump.

1. Disconnect all utilities from the existing pumping system.
2. Remove the oil-diffusion pump from the flange of the vacuum chamber.
3. With a lint-free cloth, clean the gate valve, mounting flange and vacuum chamber using a solvent recommended for oil and grease removal in high-vacuum service.
4. Be sure the control logic of the system will operate safely and properly after the installation of the cryopump. Changes to the electrical system should be made only by a qualified electrician.

Temperature Sensor Cable Assembly (Optional Accessory)

SCAI can furnish a cable assembly (optional) to connect the silicon diode temperature sensor to a controller/indicator. See the Parts section in this manual.

If you furnish a cable and the mating plug, P/N 34760, see Figure 18 for the wiring schematic. Proceed as follows:

1. Prepare the sensor cable as illustrated in Figure 7. Strip back the cable jacket to expose a 16 mm (5/8") length of lead wires. Strip the wire insulation to expose 3 mm (1/8") of wire.
2. Solder the positive lead from the controller to the gold solder cup end of one of the connector sockets. Solder the negative lead to another socket.
3. Slip the cable clamp over the end of the cable.
4. From the backside of the plug body, insert the socket with the positive lead into the #4 position in the rubber isolator. Use a small screwdriver to push the socket below the level of the rubber until it seats.
5. Insert the socket with the negative lead into the #3 position in the rubber isolator, as described above.
6. Thread the cable clamp on to the body of the plug. Use the screws to tighten the clamp against the cable jacket for strain relief.

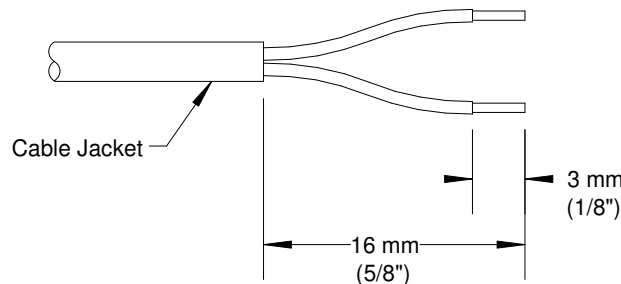

Figure 7 Prepare the Sensor Cable

Install the Cryopump

⚠ WARNING

MOUNT THE CRYOPUMP BEHIND A GATE VALVE that closes automatically if the cryopump shuts down or if there is a power failure.

⚠ WARNING

EXPLOSION HAZARD. AVOID INJURY. Prevent the buildup of static charges that could act as an ignition source for flammable gases.

The cryopump's mounting flange bolts to a gate valve that isolates the cryopump's chamber from the main vacuum chamber. This type of mounting is the most common, because it is versatile. A cryopump mounted to a valved chamber can be cooled down, kept cold or regenerated independently of the main chamber. See Figure 8.

Cryopumps mounted with gate valves are often used in high-volume production applications such as sputtering or ion implantation. The gate valve should close automatically if the cold head or the compressor stops, or if there is a power failure. The gate valve should not open automatically.

1. Be sure the mounting flange O-ring or metal gasket is in place.
2. Mount the cryopump to the isolation gate valve on the vacuum chamber.

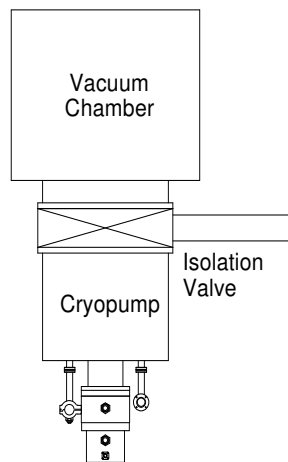

Figure 8 Cryopump Mounting

Install the Gas Lines

Tools required: Open end wrenches, 1", 1 1/8", 1 3/16"

Gas line couplings are shipped with protective dust plugs and the cryopump and compressor couplings are protected with dust caps. Do not remove the plugs and caps until the gas lines are ready to be attached. All bending and routing of gas lines should take place with plugs in place.

⚠ WARNING

AVOID INJURY. Always wear eye protection when handling pressurized gas lines and other pressurized equipment.

⚠ WARNING

EXPLOSION HAZARD. Never apply heat to a pressurized gas line or to other pressurized components.

CAUTION

PREVENT EQUIPMENT DAMAGE. Do not crimp the gas lines. Subsequent attempts to bend the gas lines can damage them.

NOTE

SCAI recommends having 99.995% pure helium gas available at the installation site in case gas needs to be added to the system. See Refrigerant Quality in Specifications in this manual.

1. SCAI furnishes identification labels for the customer to attach to the gas lines. Before installing the gas lines, identify each with its appropriate label, SUPPLY (color-coded red) or RETURN (color coded green) by applying the label adjacent to each Aeroquip coupling. See Figure 9.

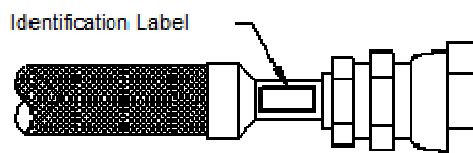

Figure 9 Attach Identification Label

2. Arrange the system components so that the gas lines will be protected from stress and traffic. Observe the minimum bend radius specified in the Gas Lines manual. Routing of gas lines should consider the need for gas line supports.
3. Remove the dust caps from the compressor supply and return gas couplings.
4. Remove the dust plugs from the couplings on one end of each of the supply and return gas lines.

CAUTION

AVOID GAS LEAKS. Check the condition of the gasket seal on the male half of each Aeroquip coupling. Be sure the gasket seal is in place and the sealing surfaces on both the male and female halves are clean before connecting. Replace the gasket seal if it is damaged or missing. Keep the gas line couplings aligned when making or breaking a coupling connection. Leaks can occur due to the weight of the gas line or due to a sharp bend near the connection

NOTE

Retain the threaded dust caps and plugs to re-cover the couplings when they are not in use. They protect the couplings from damage and prevent entry of contaminants.

5. Connect the supply gas line to the supply coupling on the compressor or to the supply gas manifold. Use two wrenches to tighten the coupling. See Figure 10.

Torque all couplings to 4.85 ± 0.7 kgf m (35 ± 5 ft. lbs.)
Tighten each coupling before proceeding to the next one.

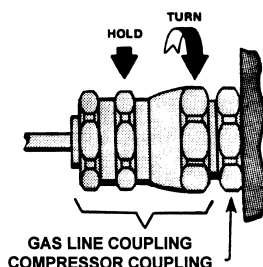

Figure 10 Connect a Gas Line to the Compressor or Cryopump

6. Connect the return gas line to the return coupling on the compressor or to the return gas manifold.
7. Remove the dust caps from the helium supply and return couplings on the cryopump. Screw the dust plugs from the gas lines into the dust caps from the cryopump and store them.
8. Connect the return gas line to the return coupling on the cryopump. Torque the coupling to 4.85 ± 0.7 kgf m (35 ± 5 ft. lbs.). See Figure 10.
9. Connect the supply gas line to the supply coupling on the cryopump. Tighten the coupling as described in Step 8.
10. Leak check all the Aeroquip coupling connections.

Install the Cold Head Cable

1. Connect one end of the cold head cable to the cold head receptacle on the compressor.
2. Connect the other end to the cold head cable receptacle on the cryopump.

Connect the Purge Gas, Vacuum and Vent Lines

⚠ WARNING

AVOID ASPHYXIATION. Be sure that the work area is will ventilated.

1. Connect a supply of clean, dry nitrogen gas to the nitrogen purge port.

⚠ WARNING

EXPLOSION HAZARD. AVOID INJURY. Never use compressed gas from a cylinder without a proper regulator. Overpressure can cause serious injury if the system equipment ruptures. Always wear eye protection when handling pressurized gas lines and other pressurized equipment.

2. Connect the roughing line to the pumpout port. Use a pipe or hose with an inside diameter as large as possible to maximize pumping speed. The roughing line should contain a valve to close to isolate the roughing pump.

3. Connect a temperature-sensor cable from the temperature controller/indicator to the temperature-sensor connector.

 WARNING
EXPLOSION HAZARD. AVOID INJURY. A relief valve or a rupture disc must always be installed on a cryopump.
Do not remove, modify, block or restrict any pressure relief devices. Material failure and resulting pressure release can cause serious injury.

CAUTION
PRESSURE HAZARD. AVOID EQUIPMENT DAMAGE. Cryopump relief valve opens at 0.14 to 0.28 kPa (1 to 2 psi) above temperature. Rupture disc bursts at 172 kPa (25 psi) above atmosphere. Check gate valve for the maximum allowable pressure difference between cryopump and chamber.

 WARNING
AVOID INJURY. If flammable, corrosive or toxic gases are cryopumped, a vent pipe must be connected to the relief valve or the rupture disc outlet. Vent to a safe location.

4. If pumping flammable, corrosive or toxic gases, connect a vent line to the pressure relief valve port of the cryopump and direct the vented gases to a safe location.

A vent line connected to the relief valve port must maintain at least a 33 mm (1.3") inside diameter for at least 40.1 mm (1.58") from the flange of the relief valve port to prevent restricting the gas flow. See Figure 11a.

If the vent line diameter is reduced beyond the 40.1-mm distance, provide a stop at the transition to prevent a broken poppet from blocking the vented gas. See Figure 11b that shows a typical stop configuration.

An aluminum vent adapter for mounting to the relief valve port provides a NW40 flange for connecting a vent line. The optional vent adapter is SCAI P/N 260936B. See Figure 11b.

5. The vent line connected to the vent adapter must have a minimum inside diameter of 22 mm (0.88") and a maximum length of 3.0 m (10 feet), and be connected to a vent manifold at atmospheric pressure.

This completes the installation of the cryopump. The system equalization pressure shown by the compressor gauge(s) after all components have been connected will determine if charging or venting is required. See the Specifications section in the compressor manual for system equalization pressures at different ambient temperatures.

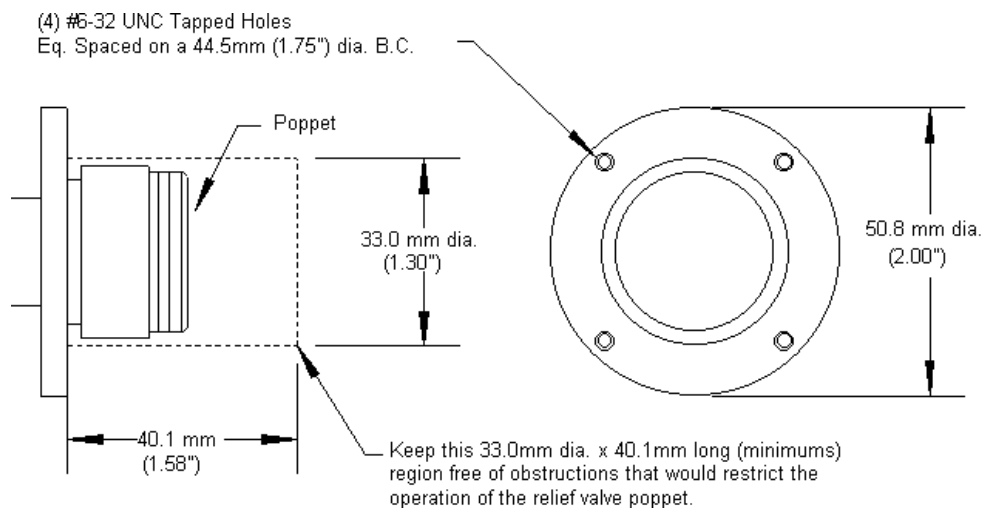

Figure 11a Relief Valve Vent Connection Detail

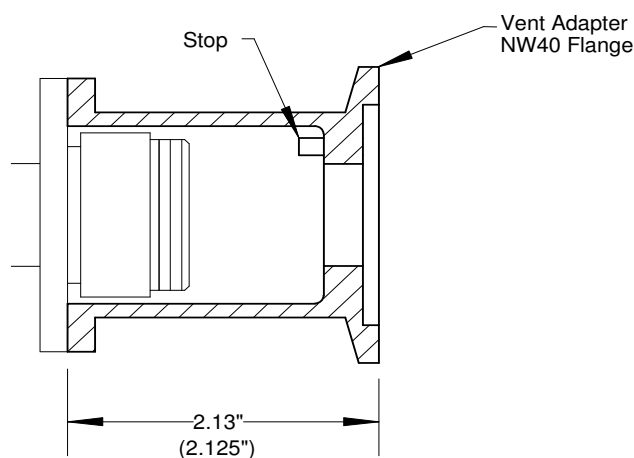

Figure 11b Vent Adapter (Optional) P/N 260936B

Remote On/Off Cable (Optional Accessory)

A remote on/off cable for the compressor can be furnished as an accessory.

To install the cable:

1. Disconnect the power to the compressor.
2. Remove the heat shrink cap from one end of the remote on/off cable. Connect the cable to the remote switch (not supplied by SCAI). Use the green conductor to ground the switch box. Switch voltage will be single phase and the same as the power source, as determined by the compressor model used in the system. See the Electrical Schematic diagram in the Compressor manual.
3. Connect the other end of the cable to the accessory receptacle on the compressor.

4. Switch on the power to the compressor.

The system can now be operated from the compressor or from the remote switch. When using the remote switch, the power switch on the compressor must be in the stop position.

5. To verify that the cable installation is correct, close the remote switch. Run the system for one minute, then stop.

NOTE

When the compressor is started by the remote on/off switch, it cannot be stopped by the compressor's switch. Open the compressor's circuit breaker to stop it locally. When the compressor is started at the compressor power switch, it cannot be stopped at the remote on/off switch.

ACCESSORIES

The Marathon[®] CP-20 Cryopump has been designed to allow its utility ports to be reconfigured in the field by the installation of various accessory options. All CP-20 pumps have three 1.33" O.D. metal seal utility ports in the base of the vacuum enclosure as shown in Figure 3. Each of these ports can be adapted to a specific function by attaching the appropriate accessory. Any accessory may be mounted to any utility port. The accessory must be properly oriented to avoid interference. The available accessories are:

<u>Description</u>	<u>SCAI Part Number</u>
Rupture disc, 172 kPa (25 psig)	260022A2
Rupture disc, elbow, 172 kPa (25 psig)	262900B1
Blank for 1.33" O.D. accessory port	260021A2
Pumpout/nitrogen purge adapter	266708A02
Standard single silicon diode temperature sensor, 4 pin	253995C2
Optional dual silicon diode temperature sensor, 10 pin, for use with Marathon [®] Cryopump Controller (MCC)	266686A1
Hydrogen vapor bulb temperature sensor (back mount)	255193C
Hydrogen vapor bulb temperature sensor (bottom mount)	263387C
Relief valve, elbow	262889A3
Blanket Heater, 500 watts, 208 V~, 190° F thermostat, with mounting springs	267553C

 **WARNING**

HIGH PRESSURE GAS HAZARD. A relief valve or a rupture disc must always be installed on a cryopump.

The cryopump will be preconfigured at the factory to customer's requirements so no assembly of components is necessary prior to installation. However, it is easy to rearrange accessories in the utility ports or to install additional accessories at a later date.

Installation

All accessories mount to the 1.33" utility ports. However, specific mounting instructions follow for installing the Pumpout/Nitrogen Purge Adapter, the Silicon Diode and the Hydrogen Vapor Bulb Temperature Sensors.

To mount an accessory to a utility port, use a 9/64" hex key wrench. Hold the accessory and a new copper gasket in place on the utility port. Fasten the flange to the tapped port with six flat washers, lock washers, and #8-32UNC x 5/8" long hex socket head cap screws. Tighten the screws with the wrench.

Pumpout/Nitrogen Purge Adapter

Tool required: 9/64" Hex key wrench

Installation Procedure: Slip a new copper gasket over the tube extending from the adapter. Insert the tube into the appropriate utility port and gently work the tube through a hole in the first-stage cryopanel. This will allow the adapter's flange to mount to the utility port. Use a flat washer and lock washer with the #8-32UNC x 5/8" long hex socket head cap screws. Tighten them into the tapped utility port flange with the wrench.

Silicon Diode or Hydrogen Vapor Bulb Temperature Sensor

Tools required: 9/64" Hex key wrench
7 mm Combination wrench
4 mm Hex key wrench
Medium flat-blade screwdriver
Bent tip needle nose pliers

Installation Procedure:

1. Remove the inlet louver and both cryopanel following the procedure in the Maintenance section.
2. Remove the old copper gasket. Slip a new copper gasket over the end of the temperature probe.
3. Feed the sensor probe through the utility port into the cryopump enclosure.
4. Remove the screw from the sensor probe. Insert the screw through the countersunk hole on the face of the cold head's second-stage heat station. (Diode assemblies for use with a Marathon Cryopump Controller have two diodes. Attach the shorter diode to the first-stage heat station. Attach the longer diode to the second-stage heat station.)
5. Slip the small indium gasket over the protruding length of the screw.
6. Bring the copper sensor mounting block off the sensor probe to meet the screw and thread the screw into the probe. Hold the probe with the needle nose pliers. Tighten the screw into the probe using the screwdriver. Make sure the indium gasket is crushed between the probe block and the cold head heat station.
7. Reinstall the cryopanel and the inlet louver following the procedure in the Maintenance section.

OPERATION

WARNING

SPECIAL PROCEDURES for CRYOPUMPING OXYGEN and OZONE

Be aware of the presence and concentration of oxygen and/or ozone in the process gases being cryopumped. If oxygen concentrations exceed 20% (richer than in normal air), the cryopump system must be constructed, operated and maintained according to oxygen manufacturer's standards. This includes materials of construction and approved vacuum pump oil for oxygen service.

Cryopumping oxygen or ozone requires special precautions and frequent regenerations. Ozone can react violently with charcoal. Daily regeneration may be required. Use an inert gas purge during regeneration at a sufficient flow rate to minimize the explosion hazard.

Do not operate any ignition source (electric heaters, ionization gauges, etc.) in the cryopump side of the high vacuum valve.

Be aware also that an ionizing process being cryopumped may produce ozone and create explosive conditions.

Ozone can be identified by a "fresh air" odor as detected during a thunderstorm or pungent odors similar to those from arc welding. Popping and/or cracking sounds, like from arcing or welding, during regeneration indicate ozone's presence.

If ozone is present:

- a. Reduce the oxygen content in the process gas mixture to the lowest level allowable.
- b. Follow all of the above precautions for oxygen. The cryopump must be regenerated daily.

Contact a SCAI Service Center if you have any questions.

Prestart Check

1. Check that the cooling water lines are connected to the compressor. Turn on the coolant and check the lines for leaks. Tighten fittings if necessary. See Specifications in the Compressor manual for cooling requirements.
2. Check that all electric cables are connected:
 - a. Compressor power cable.
 - b. Cold head cable.
 - c. Remote on/off cable, if installed.
3. Check that the circuit breaker is closed.
4. When the compressor is at room temperature, 20°C (68°F), the pressure gauge(s) should indicate the equalization pressure. See Helium Gas Pressures in the Specifications section of the Compressor manual. Higher or lower temperatures will result in correspondingly higher or lower pressures, but these pressure changes are normal. Abnormally lower readings indicate that some of the gas charge has been lost. Refer to the Maintenance section for instructions on charging, cleaning and leak checking.

The cryopump should be mounted to a gate valve attached to the vacuum chamber so that the cryopump can be isolated and left running while the pressure in the main vacuum chamber cycles from atmospheric to crossover pressure. See Figure 12.

1. Connect roughing valve (V2) and rough pump to pump-out port of the cryopump. See Figure 10. A dry vacuum pump is recommended to provide rough vacuum pumping. If oil-sealed vacuum pump must be used, always use a suitable adsorbent inlet trap to prevent oil from backstreaming into the cryopump.

CAUTION

AVOID EQUIPMENT DAMAGE. Oil backstreaming from the roughing pump can contaminate the cryopump. Use dry roughing pump or suitable adsorbent inlet trap if oil sealed mechanical roughing pump must be used.

2. Connect purge valve (V3) and nitrogen purge supply to the purge port of the cryopump. See Figure 12. The purge gas must be clean, dry nitrogen. The nitrogen supply must provide 2 to 6 scfm.
3. Review application of the cryopump. If potentially corrosive, flammable or toxic gases are captured by the cryopump, the relief valve must be properly ducted to outdoor atmosphere. The cryopump will discharge all the captured gases through the relief valve in a few minutes during regeneration. Be sure the work area is well ventilated. A cryopump used in small rooms or otherwise poorly ventilated work areas must have the relief valve properly ducted to outdoor atmosphere.
4. Connect cable to diode temperature sensor assembly for monitoring cryopump temperature.

Startup

 **WARNING**

AVOID ASPHYXIATION. Be sure the work area is well ventilated. Otherwise, duct relief valve or rupture disk directly to outdoor atmosphere.

 **WARNING**

EXPLOSION HAZARD. AVOID INJURY. Cryopumped gases are retained only while the cryopump is cold. Cryopumped gases may be toxic, flammable or may produce high pressures when the cryopump is warmed to ambient temperature.

 **WARNING**

EXPLOSION HAZARD. AVOID INJURY. Do not remove, modify, block or restrict any pressure relief devices. Material failure and resulting pressure release can cause serious injury.

⚠ WARNING

EXPLOSION HAZARD. AVOID INJURY. If flammable, corrosive or toxic gases are cryopumped, a vent pipe must be connected to the relief valve or the rupture disc outlet. Vent to a safe location.

⚠ WARNING

EXPLOSION HAZARD. AVOID INJURY. Provide a fail-safe, automatic shutdown of all ignition sources in the vacuum chamber when the cryopump shuts down. For example, turn off ionization gauges and electric heaters.

⚠ WARNING

AVOID INJURY. Establish safe handling procedures for cryopanel and louvers that may hold toxic or radioactive gases. Contamination by some gases can result in serious injury or death. See the Cryopump Handling and Shipping procedure in the Maintenance section of this technical manual. Procedures in this manual apply only to uncontaminated cryopumps.

⚠ WARNING

AVOID INJURY. Cryopumped gases will exit at extremely cold temperatures when the cryopump is warmed. Keep all personnel away from gases exiting the cryopump relief valve during regeneration to prevent injury.

1. Close gate valve (V1), close purge valve (V3), and open the roughing valve (V2). Turn on rough vacuum pump. Rough pump the cryopump to 5×10^{-2} torr (50 microns of mercury) to confirm there are no leaks in the cryopump installation.
2. Crossover is the pressure at which the isolating gate valve is opened to begin cryopumping of the main vacuum chamber.

To determine the maximum crossover pressure, divide the crossover rating for the cryopump by the volume of the main vacuum chamber.

$$\text{Crossover Pressure (torr)} \leq \frac{\text{Crossover Rating (torr-liters)}}{\text{Chamber Volume (liters)}}$$

The crossover rating for the Marathon[®] CP-20 Cryopump for nitrogen is 400 torr-liters. If the volume of the main chamber is 400 liters, the crossover pressure should be 1 torr or less.

When a suitable crossover pressure has been reached, open the gate valve to expose the cryopump to the main vacuum chamber. As a check, if the volume of gases in the main chamber does not raise the second-stage temperature above 20 K, then the crossover pressure is correct.

Regeneration

Regeneration removes the frozen, trapped gases from the cryopump and returns it to its full, rated capacity. The process has four phases: warm-up, purge, evacuate and cooldown. Because the time between regenerations depends upon the cryopump application, the user must determine the most suitable interval between regeneration cycles. Cryopumps in many applications will operate two weeks or more before regeneration becomes necessary.

NOTE

This section of regeneration instructions pertain to cryopumps that are equipped with typical manual valves that are installed and controlled by the operator.

For Marathon CP cryopumps, which are operated with a Marathon Cryopump Controller (MCC), refer to Marathon Cryopump Controller Regeneration reference Guide, P/N 267147A.

Usually, regeneration is initiated when the second-stage temperature rises to 20 K, or when the pumping speed decreases to 50% of its initial value. If the process gas flow is constant, the pumping speed is one-half when the operating pressure doubles.

Regeneration: Warm-Up Phase



EXPLOSION HAZARD. AVOID INJURY. Use a fail-safe, automatic nitrogen purge to immediately dilute toxic and flammable gases.

1. See Figure 12. Close the gate valve to isolate the cryopump from the main vacuum chamber.
2. Stop the cryopump by stopping the compressor. If more than one cryopump is operating from one compressor, stop the cryopump that is to be regenerated by turning off that specific valve motor using the controls on the compressor.
3. Open the nitrogen purge valve. If there has been a large amount of gas captured in the cryopump, it may take several minutes until gas begins to vent from the relief valve. Gas flow from the relief valve will increase rapidly for a few minutes as the frozen gases vaporize from the cryopanel. In most cases, almost all the captured gases will have exited the cryopump in 15 to 30 minutes.

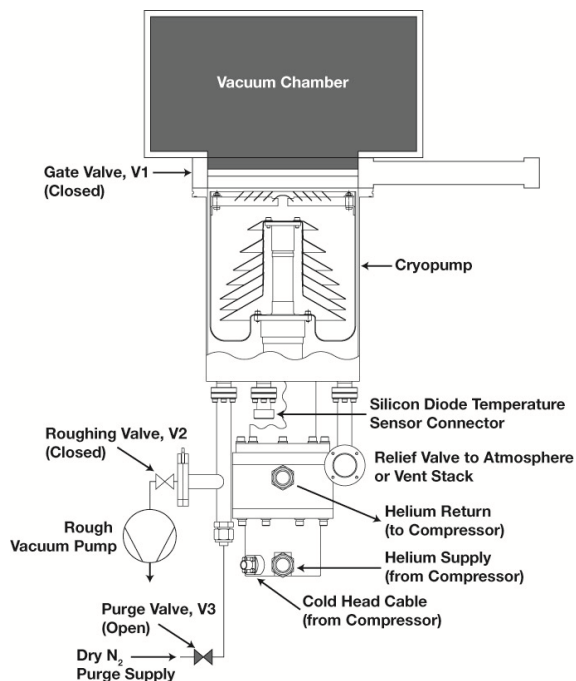

Figure 12 Warm Up and Purge the Cryopump

4. Allow the second-stage temperature to rise to 305 K/290 K for effective desorption of gases from the charcoal.

Regeneration: Purge Phase

For safety and minimum regeneration cycle time, continue purging the cryopump with dry nitrogen gas. The purge port directs the nitrogen onto the charcoal coating of the second stage cryopanel. Nitrogen purging hastens regeneration and displaces residual adsorbed gases from the charcoal.

Nitrogen purging dilutes hydrogen, oxygen and other reactive or poisonous gases that have been captured in the cryopump. Vent all purged gases safely through the pressure relief valve to a suitable vent system. Nitrogen purging should continue until the cryopump reaches room temperature. The operator must determine the gases being cryopumped and safely vent toxic gases.

There are two recommended purge methods: nitrogen purge or nitrogen purge plus heating the outside of the cryopump. Nitrogen purging and an outside heat source, such as a blanket heater, is the best method for most high-vacuum systems because it cleans the cryopump effectively and rapidly. Nitrogen purge valve and blanket heater are available as cryopump accessories.

Purging with nitrogen only:

1. Use a nitrogen supply to break the vacuum and warm up the cryopump. Nitrogen purge supply should be sized to deliver 2 to 6 scfm.

Purging with nitrogen and a blanket heater:

1. Follow instructions for "Purging with nitrogen only." Additionally, install an insulated blanket heater in direct contact with the external surface of the cryopump enclosure and operate it with a thermostat. See the Accessories and Parts sections in this manual for blanket heater.
2. When the second panel temperature reaches 310 K, turn off the heater.

Regeneration: Evacuation Phase

1. See Figure 13. Open rough valve (V2) and evacuate for at least 30 minutes at 5×10^{-1} torr to fully desorb gases from the cryopump. Bleed in a reduced flow of dry nitrogen gas through the purge port (V3) or into the roughing pump manifold to maintain 5×10^{-1} torr.

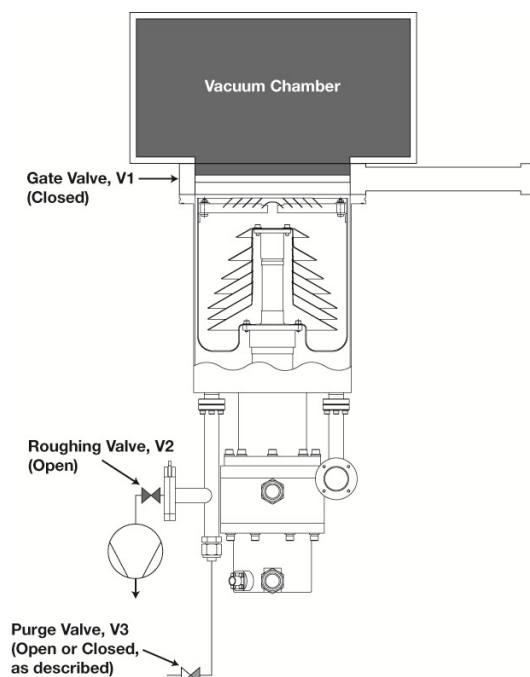

Figure 13 Evacuate the Cryopump

2. Close the nitrogen purge valve (V3). Evacuate the cryopump to a pressure of 5×10^{-2} torr (50 microns of mercury).
3. Check the rate of pressure rise in the cryopump vacuum enclosure. Close the roughing valve (V2) and the purge valve (V3). Monitor the pressure in the cryopump vacuum enclosure. If the pressure rises faster than 1×10^{-2} torr/min (10 microns/minute), open roughing valve (V2) and rough pump the cryopump for an additional 10 minutes and repeat the test.

Regeneration: Cooldown Phase

1. Start the cryopump by starting the compressor. If more than one cryopump is connected to the compressor, start the cryopump by turning on the appropriate switch on the compressor. Cool down the cryopump with the main vacuum chamber gate valve (V1) closed.

2. Monitor the pressure inside the cryopump chamber. If it rises above 0.1 torr, (100 microns), turn off the cryopump and go to Evacuation Phase, Step 2.
3. Rough pump the vacuum chamber down to crossover pressure, or lower, while the cryopump cools down.

During cool down, residual gases in the cryopump are captured (frozen). Pressure in the cryopump drops to low levels before the cryopump reaches minimum temperature. Cooldown time to 20 K for the Marathon[®] CP-20 cryopump is approximately 190 minutes.

Regeneration: Crossover

1. After the cryopump has cooled down to minimum temperature and the main vacuum chamber has been rough pumped to crossover pressure, open the gate valve. The cryopump is now operating in steady state. See Figure 14.

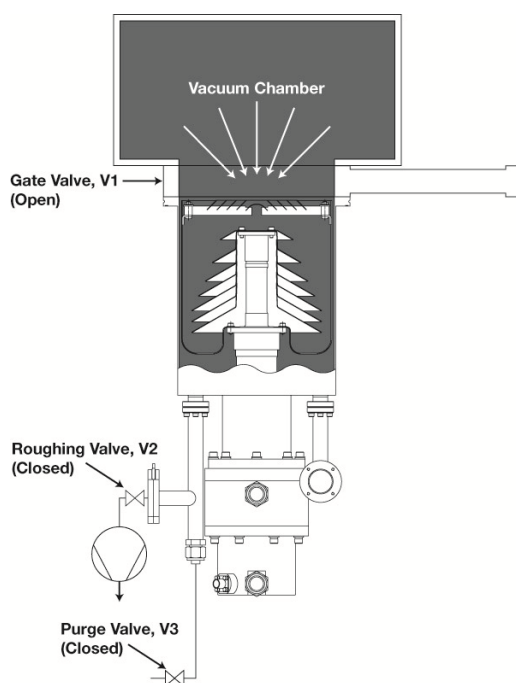

Figure 14 Cryopump Crossover

2. During steady-state cryopumping, monitor the system pressure and second-stage temperature. When frozen gases and water vapor form deposits on the cryopanel, the cryopanel temperature may rise, causing the partial pressure of the gases to increase. To maintain an adequate vacuum in the system, the second-stage temperature typically must remain below 20 K.

Vacuum Baking**CAUTION**

PREVENT EQUIPMENT DAMAGE. Do not heat cryopanel and cylinder assemblies above 80°C (176°F).

If pressures below 10^{-7} Torr are required, it is recommended to vacuum bake the vacuum chamber walls and the cryopump vacuum enclosure to drive off water vapor that has adsorbed onto them. During this process, a vacuum of less than 1 torr is preferred. Cryopanel and cylinder assemblies may be heated to 80°C (176°F).

Ultra High Vacuum (UHV) cryopumps have connections that are all copper gasketed. Vacuum chambers with UHV cryopumps can be baked out to 150° C while the cryopump is running. Typically, the cryopump continues to run after the chamber cools down, resulting in very low pressures.

Restarting after a Power Failure

The compressor is designed to restart immediately after power has been restored if it has shut down due to a power interruption. The connected cryopump will also restart.

If the compressor stops for other reasons, refer to the Troubleshooting section in the Compressor manual.

Typical cryopumps operating at less than 14 K have so little heat input that the cold head can stop, or “coast”, for up to 5 minutes without releasing frozen deposits from the panels. If the cold head is operating at a higher temperature, it has a higher heat load and therefore warms up faster.

Helium or hydrogen may be released from the charcoal before the other gases and thus shorten the coast time. If the pressure has risen to 1×10^{-2} torr, the cryopump must be warmed up and regenerated after power has been restored; otherwise, it will not operate correctly.

In most applications, the operator establishes upper pressure or temperature limits for operations that designate when the cryopump should be regenerated and when it should be allowed to re-cool following a power interruption. Typical temperature limits are 20 K to 60 K depending on the gases being pumped.

During power failures, the gate valve and all other valves should be closed to isolate the cryopump and reduce pressure increases in the vacuum chamber. If regeneration is required, follow the procedure in the Regeneration section of this manual.

WARNING

MOUNT THE CRYOPUMP BEHIND A GATE VALVE that closes automatically if the cold head or compressor shuts down or if there is a power failure.

The operator must configure the gate valve controls to provide the proper function in the event of an electrical power interruption. Typically, the gate valve is arranged to close in the event of electrical power interruption.

System Shutdown

1. Close the gate valve to isolate the cryopump from the main vacuum chamber.
2. Stop the compressor. The cryopump will stop.
3. Expect gas release through the cryopump's pressure relief valve as described in the section Regeneration: Warm-up Phase.
4. Begin nitrogen gas purge of the cryopump as described in Regeneration: Purge Phase, to dilute hazardous gases.

(This page is intentionally blank.)

MAINTENANCE

Cryopump Handling and Shipping

We at Sumitomo (SHI) Cryogenics of America, Inc. appreciate your buying and using our cryopumps. We are always available to answer questions regarding use or service of the equipment. Also, our Service Centers are prepared to maintain, repair or exchange your cryopumps when service is required, provided no hazardous materials are present in your cryopumps.

Because SCAI is concerned with the safety of its employees and our legal responsibilities, we must remind you of your obligations regarding the handling of hazardous materials. ***SCAI is not licensed to accept and cannot accept, store or dispose of hazardous materials generated by others.***

Please review the regulations that pertain to the transportation of hazardous wastes. If you determine that these regulations apply to the cryopump in question and a hazardous waste manifest would be required, SCAI cannot and will not accept the shipment. If returned goods that should have been identified by a hazardous materials manifest arrive at SCAI, they will not be accepted.

If a cryopump has been exposed to hazardous materials, it is generally possible to render the pump safe for handling by a combination of inert gas purging, removal and proper disposal of the 2nd-stage cryopanel and cleaning of the surfaces of the cryopump that have been exposed to hazardous materials. Decontamination and cleaning of the exposed surfaces must be accomplished in accordance with methods recommended in Federal Government Hazardous Material Procedures.

If you are returning a cryopump to SCAI, please contact the nearest Service Center for a Return Authorization Number prior to shipment. Cryopumps being returned to SCAI shall be accompanied by a letter listing the hazardous material(s) to which the cryopump has been exposed and certifying that the cryopump has been decontaminated in accordance with procedures meeting Federal Government requirements. A copy of the certification letter shall be attached to the packing list affixed to the outside of the shipping container.

We ask your cooperation in handling potentially hazardous materials in ways that are safe, proper and in accordance with prevailing laws. We will work with you to minimize any inconvenience caused by our policy requirements, and we are always available for further questions and discussion.

Sumitomo (SHI) Cryogenics of America, Inc.

⚠ WARNING

AVOID INJURY. Establish safe handling procedures for cryopanel and louvers that may hold toxic or radioactive gases. Contamination by some gases can result in serious injury or death. See the Cryopump Handling and Shipping procedure in the Maintenance section of this technical manual. Procedures in this manual apply only to uncontaminated cryopumps.

⚠ WARNING

AVOID INJURY. When handling pressurized gas lines and other pressurized equipment, always wear eye protection. Never apply heat to a pressurized gas line or other pressurized components.

⚠ WARNING

AVOID INJURY. Use two wrenches when disconnecting a gas line coupling to avoid loosening the cold head coupling. Gas pressure can project the coupling with enough force to cause serious injury.

⚠ WARNING

EXPLOSION HAZARD. AVOID INJURY. Disconnect the gas lines from the cold head only when the cold head is stopped and warmed to room temperature. Disconnecting the cold head while it is cold can create excessively high internal pressure as the gas warms. Material failure and uncontrolled pressure release can cause serious injury.

⚠ WARNING

EXPLOSION HAZARD. AVOID INJURY. The compressor is charged with helium gas. Except when disconnecting adsorber or gas lines, vent the compressor to atmospheric pressure before disassembly. Uncontrolled pressure release can cause serious injury.

⚠ WARNING

EXPLOSION HAZARD. AVOID INJURY. Never use compressed gas from a cylinder without a proper regulator. Overpressure can cause serious injury if the system equipment ruptures.

⚠ WARNING

AVOID INJURY FROM BURNS by allowing the compressor to cool for ½ hour after shutdown before removing the cover for maintenance.

CAUTION

PRESERVE YOUR WARRANTY. Modification to equipment without the consent of the manufacturer will void the warranty.

Specifications require the use of 99.995% pure helium gas. Using a lesser quality of helium can damage the system and void the warranty.

CAUTION

AVOID SYSTEM CONTAMINATION. Follow the charging and venting procedures to prevent reversed flow of system gas. Reversed flow can result in contamination of the system with compressor oil.

Do not charge through the supply coupling. Do not vent through the return coupling.

CAUTION

PREVENT SYSTEM MALFUNCTION. Repeatedly charging the system with helium gas rather than locating and repairing gas leaks can cause a malfunction. Impurities are introduced at an abnormal rate and may freeze in the cold head

CAUTION

AVOID REFRIGERANT LEAKS. Check the condition of the gasket seal on the male half of each Aeroquip coupling. Be sure the gasket seal is in place and the sealing surfaces on both the male and female halves are clean before connecting. Replace the gasket seal if it is damaged or missing. Keep the gas line couplings aligned when making or breaking a coupling connection. Leaks can occur due to the weight of the gas line or due to a sharp bend near the connection.

Compressor Adsorber Replacement

Replacement of the adsorber in the compressor capsule is scheduled, required maintenance. Refer to the replacing procedure in the Maintenance section of the Compressor manual.

 WARNING

AVOID INJURY. The adsorber is charged with helium gas. Follow the used adsorber venting procedure for safe disposal of the used adsorber.

Remove the Cryopump from the Vacuum Chamber**NOTE**

All of the following procedures apply only to cryopumps that have not been contaminated by toxic or radioactive gases.

1. Follow the procedure in Regeneration: Warm-Up Phase, in the Operation section of this manual.

2. Using two wrenches, disconnect the gas lines from the cryopump. Install dust caps and plugs on the cold head and gas line couplings. See the next section.
3. Disconnect the cold head cable, vacuum roughing line, nitrogen purge line and temperature sensor cable from the cryopump.
4. Support the weight of the cryopump and remove the mounting hardware.
5. Pull the cryopump clear of the vacuum chamber. Protect the surfaces of the mating, mounting flanges.

Disconnect the Gas Lines

Tools required: Open end wrenches 1", 1 1/8", 1 3/16".

⚠ WARNING

AVOID INJURY. Disconnect gas lines only when the compressor is stopped. Disconnecting the cold head while it is cold can create excessively high internal pressure as the gas warms. Material failure and uncontrolled pressure release can cause serious injury.

⚠ WARNING

AVOID INJURY. Use two wrenches when disconnecting a gas line coupling to avoid loosening the cold head coupling. Gas pressure can project the coupling with enough force to cause serious injury.

CAUTION

AVOID GAS LEAKS. Keep the gas line couplings aligned when making or breaking a coupling connection. Leaks can occur due to the weight of the gas line or due to a sharp bend near the connection. Crimping from repeated bending a repositioning can cause damage to gas lines.

1. Always use two wrenches. Use one wrench to hold the cold head coupling. Use the second wrench on the gas line coupling nut to break the connection. See Figure 15.
2. After breaking the connection, hold the coupling adapter with one wrench. Remove the gas line coupling from the cold head coupling with the second wrench. See Figure 16. Remove both gas lines from the cold head.

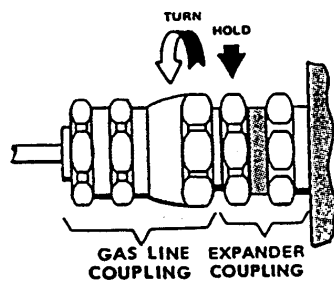

Figure 15 Break the Gas Line Connection from the Cold Head

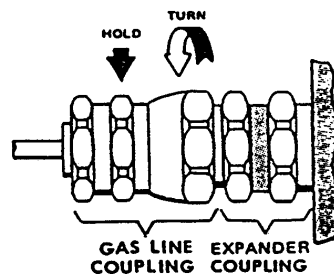

Figure 16 Disconnect the Gas Line from the Cold Head

3. Screw dust plugs finger tight into the Aeroquip couplings on the gas lines.
4. If the cold head is not to be vented, screw dust caps onto its two Aeroquip couplings.

Cryopanel Maintenance

Tools required: 7 mm combination wrench
5 mm hex key wrench
4 mm Hex key wrench
Flat nose pliers
Medium slotted offset screwdriver
Metric socket head torque wrench (for reassembly)

The following procedure covers complete disassembly of the cryopump. The steps are in the required sequence. If complete disassembly will not be required, stop at the appropriate step. The cold head need not be removed from the cryopump to remove the cryopanel.

Although the cryopanel requires no planned maintenance schedule, they should be removed and cleaned if oils or other contaminants have gotten onto them and do not come off during regeneration. If the charcoal inside the second-stage cryopanel remains contaminated, the panel must be replaced.

The charcoal may degrade substantially if the minimum pressure is higher than normal (1×10^{-4} torr or 0.1 microns of mercury) during cryopumping. If the charcoal has degraded, replace the second-stage cryopanel.

 **WARNING**

EXPLOSION HAZARD. AVOID INJURY. Cryopumped gases are retained only while the cryopump is cold. Cryopumped gases may be toxic, flammable or may produce high pressures when the cryopump is warmed to ambient temperature.

 **WARNING**

EXPLOSION HAZARD. AVOID INJURY. Do not remove, modify, block or restrict any pressure relief devices. Material failure and resulting pressure release can cause serious injury.

 **WARNING**

EXPLOSION HAZARD. AVOID INJURY. If flammable, corrosive or toxic gases are cryopumped, a vent pipe must be connected to the relief valve or rupture disc outlet. Vent to a safe location.

CAUTION

AVOID CONTAMINATION. When handling any vacuum surfaces, wear clean, lint-free gloves to prevent contamination. If the surfaces of the cryopanel become fingerprinted during unpacking or handling, clean them with a solvent recommended for oil and grease removal in high-vacuum service.

Disassemble and Clean the Cryopanel**⚠ WARNING**

AVOID INJURY. Extreme cold can cause frostbite. Cryopanel remains cold for some time after power is turned off. Allow sufficient time for warm-up before disassembly.

The cryopump has been warmed up, vented to atmospheric pressure and removed from the vacuum chamber.

1. Wear contaminant-free gloves. Use the 7-mm wrench to remove the nuts and washers from the louver. Lift the louver from the first-stage cryopanel.

NOTE

When removing each cryopanel, inspect the indium gaskets for damage. If they remain intact, reuse them; otherwise, replace them. Wear clean, lint-free gloves. At reassembly, align the new gaskets with the bolt holes. Press them down and smooth them into place.

2. Use the 4-mm wrench to remove the screws and washers from the second-stage cryopanel. Lift the cryopanel from its mounting bracket. Inspect the indium gaskets.
3. Use the 4-mm hex key wrench to remove the screws and washers holding the first-stage cryopanel to the cold head's first-stage heat station. Remove the cryopanel and the indium gasket. Inspect the indium gasket.
4. Clean the nickel-plated surfaces of the cryopanel and the louver with a solvent recommended for oil and grease removal in high-vacuum service. Clean painted surfaces by wiping with a clean, dry, contaminant-free cloth. Do not use solvents to clean painted surfaces.
5. Replace the cryopanel if they are corroded or contaminated with oil.

This completes the procedure for disassembling the cryopump and cleaning the cryopanel.

Reassemble the Cryopanel

Reassemble the parts in reverse order as follows: First-Stage Cryopanel, Second-Stage Cryopanel and Louver.

1. Install the first-stage cryopanel to the cold head's first-stage heat station. Be certain to align the indium gasket with the bolt holes. Press the gasket down and smooth it into place. Install the stainless steel Belleville washers.

Torque the M4 x 0.7 x 10-mm socket head cap screws to 3.4 N-m (30 in. lb.).

2. Install the second-stage cryopanel to the cold head's second-stage heat station. Be certain to install and align the indium gaskets with the bolt holes. Press the gaskets down and smooth them into place. Install the stainless steel Belleville washers.

Torque the M4 x 0.7 x 10-mm socket head cap screws for the second-stage cryopanel to 3.4 N-m (30 in. lb.).

3. Install the inlet louver after checking that the indium gaskets are in place. Install the stainless steel flat washers and lock washers.

Torque the M4 x 0.7 hex nuts to fasten the inlet louver to the first-stage cryopanel to 1.4 N-m (12.5 in. lb).

This completes the procedure for reassembling the cryopanel.

Clean the Relief Valve

WARNING

EXPLOSION HAZARD. AVOID INJURY. Establish a cleaning schedule based on pressure rise to keep the relief valve free of dirt generated during the vacuum process.

Tool required: Flat nose pliers.

The relief valve is designed to open and vent gases if the pressure rises to 7 kPa (1 psig). The valve should be checked and cleaned if dirt prevents proper seating and causes leaks, indicated by the inability to attain an adequate vacuum level when rough pumping.

1. If the relief valve leaks, remove it by unscrewing the knurled cap.
2. Remove the snap ring and the spring. Disassemble the relief valve assembly. Remove both O-rings.
3. Clean the O-ring seats and the entire assembly with a solvent on a clean, lint-free cloth. Blow the parts dry with dry, nitrogen gas.
4. Wipe both O-rings with a dry, clean, lint-free cloth. Examine both and replace them if they are damaged. Be sure the seating O-ring has no dirt inclusions embedded in its surface. Apply vacuum grease sparingly to the O-rings. Use only enough grease to give a shiny appearance to the O-rings. Remove excess grease with a dry, clean, lint-free cloth.
5. Reassemble the valve. Reinstall it, turning the knurled cap only hand tight.

Clean the Relief Valve's Filter Screen

Inspect the filter screen whenever the cryopump's first stage cryopanel is removed. If there is any visible debris accumulated on the screen, remove the relief valve as described above. Blow dry, compressed air into the open end of the relief valve elbow to remove any accumulated debris from the screen. If this procedure does not remove all the debris from the screen, replace the relief valve base subassembly.

Rupture Disc

A rupture disc is normally supplied with copper-gasketed cryopumps. Because no threads or O-rings interconnect with the vacuum area, rupture discs form a tighter seal than do relief valves.

As the cryopump warms to ambient temperature, the rupture disc automatically bursts if the cryopump chamber pressure reaches 125 kPa (18 psig). Once the disc has failed, the assembly must be replaced.

1. Remove the six socket head cap screws on the utility port flange.
2. Remove the rupture disc assembly, including the copper gasket which forms the seal between the two knife edges of the flange.
3. With a new rupture disc assembly, reinstall the parts in reverse order.

Standard Silicon Diode

An encapsulated silicon diode is furnished to measure the temperature of the cold head's second-stage heat station. The diode signal may be used in a control system to automatically shut down the cryopump system for regeneration. It may also be connected to a voltmeter or a digital temperature readout. For further information on automatic regeneration, consult SCAI.

Functional Check

Tools required: Current source, 10 microamps \pm 1%
 Digital voltmeter, 3 1/2 digits.

To check if the diode is functioning properly:

1. Connect the positive side of a 10-microamp DC current source to pin A of the diode connector. Connect the negative side to pin D. See Figure 17.
2. Measure the output voltage across the same two pins. The output voltage should range from 0.54 to 0.59 volts DC at room temperature, 20 to 24°C (68 to 76°F). If the voltage is outside this range, replace the diode.

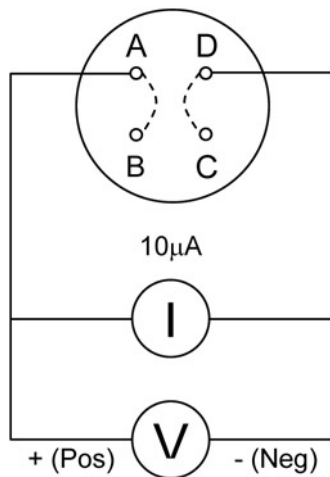

Figure 17 Check the Standard Silicon Diode

Optional Dual Silicon Diode used with a Marathon® Cryopump Controller (MCC)

An encapsulated, dual, silicon diode is furnished to measure the temperatures of the first and second stage heat stations when the cryopump is connected to a Marathon® Cryopump Controller. The diode signal is required for the control system to automatically initiate regeneration.

Functional Check of the Dual Silicon Diodes

Tools required: Current source, 10 microamps \pm 1%
Digital voltmeter, 3 1/2 digits.

To check if the first stage diode is functioning properly:

1. Connect the positive side of a 10-microamp DC current source to pin B of the diode connector. Connect the negative side to pin D. See Figure 18.
2. Measure the output voltage across the same two pins. The output voltage should range from 0.54 to 0.59 volts DC at room temperature, 20 to 24°C (68 to 76°F).
If the voltage is outside this range, replace the dual diode.

To check if the second-stage diode is functioning properly:

3. Connect the positive side of a 10-microamp DC current source to pin H of the diode connector. Connect the negative side to pin F. See Figure 18.
4. Measure the output voltage across the same two pins. The output voltage should range from 0.54 to 0.59 volts DC at room temperature, 20 to 24°C (68 to 76°F).
If the voltage is outside this range, replace the dual diode.

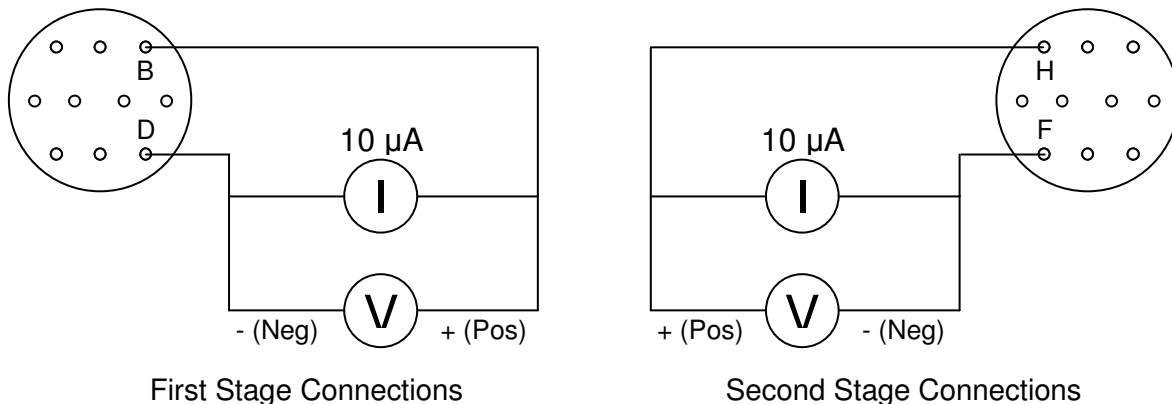

Figure 18 Check the Dual Silicon Diodes

Hydrogen Vapor Bulb

To check if the vapor bulb is functioning properly:

1. Allow the cryopump to warm to room temperature. Follow the procedure in System Shutdown in the Operation section.
2. Read the gauge. The gauge should indicate 50 psia or greater on the pressure scale.
3. Replace the complete vapor bulb assembly if the pressure is below 50 psia.

Cold Head Maintenance

Tools required: 5-mm hex key wrench
Flat blade screwdriver
Metric socket head torque wrench.

Cold head maintenance can be performed and the displacer can be removed from the cryopump without relieving the vacuum in the cryopump. Allow the cryopump to warm to room temperature. Cryopanel needs not be removed to withdraw the valve motor and the displacer from the cold head cylinder. See Figure 3.

Cold Head Removal from the Cryopump

The complete cold head can be removed from the cryopump, if required. The cryopanel has been removed from the cryopump. Disconnect the gas lines using two wrenches and following the procedure Disconnect the Gas Lines.

1. Use a screwdriver to remove the M4 x 0.7 flat head, brass screw from the cold head's second-stage heat station. Remove the diode housing and indium gasket. Inspect the gasket.
2. Use a 5-mm hex key wrench to remove the socket head cap screws and washers holding the cold head to the vacuum enclosure. Carefully withdraw the cold head from the cryopump.

Cold Head Installation into the Cryopump

Procedure for cold head installation:

1. Examine the O-ring between the cold head's warm flange and the flange of the vacuum enclosure. Replace the O-ring if it is damaged. Wipe the O-ring with a light coat of vacuum grease. Insert the cold head into the vacuum enclosure.
2. Insert the flat washers, lock washers and hex socket head cap screws into the vacuum enclosure assembly flange and hand-tighten the cap screws.
3. Using a cross pattern, tighten diametrically opposed cap screws. Torque them to 18.6 N-m (165 in. lbs.).
4. Insert the diode housing into the second-stage heat station. Place the indium gasket over the hole in the heat station. Install the flat head, brass, M4 x 0.7 x 10-mm long screw. Tighten with a screwdriver.
6. Reconnect the gas lines. Use two wrenches.

Charging and Venting

Charging or venting is required whenever the equalization pressure of the system is outside the range as stated in the Specifications section of the compressor manual. See these Specifications for equalization pressures at different ambient temperatures.

Venting a component to atmospheric pressure is required if leaking self-sealing couplings need to be disassembled for repairs. Refer to the appropriate component manual.

⚠ WARNING

EXPLOSION HAZARD. AVOID INJURY. Never use compressed gas from a cylinder without a proper regulator. Overpressure can cause serious injury if the system equipment ruptures. Always wear eye protection when handling pressurized gas lines and other pressurized equipment.

CAUTION

PREVENT EQUIPMENT DAMAGE. For compressors with a charge/vent fitting, use one wrench to support the body of the charge/vent fitting while removing or installing the dust plug or the charge line nut with the other wrench. Do not over torque.

CAUTION

AVOID CONTAMINATION. Follow charging and venting procedure to prevent reversed flow of system gas. Reversed flow can result in contamination of the system with compressor oil.

Do not charge through the supply coupling. Do not vent through the return coupling.

NOTE

Optional adapter fittings to charge, vent and cleanup the system are available from SCAI.

Charging Procedure

CAUTION

PREVENT SYSTEM MALFUNCTION. Repeatedly charging the system with helium gas rather than locating and repairing gas leaks can cause a malfunction. Impurities are introduced at an abnormal rate and can freeze in the cold head.

Refer to the Maintenance section of the Compressor manual.

Venting Procedure to Adjust the Equalization Pressure

Refer to the Maintenance section of the Compressor manual.

Gas Cleanup

These procedures are required if leaks in the factory charged gas lines, the cryopump or the compressor have reduced the pressure to less than 140 kPa (20 psig). Parts that have lost their pressure must not be assembled into the system until they have been cleaned, to avoid contaminating the system with air and water vapor.

Gas Cleanup of the Gas Lines

See the procedure in the Maintenance section of the Gas Lines manual.

Gas Cleanup of the Cold Head

Tools required: Open end wrenches 1", 1 1/8", 1 3/16"

NOTE

This procedure can be done only after the cryopump has warmed to room temperature.

This procedure is required every time the cold head has been opened to the atmosphere, to avoid contaminating the system with air and water vapor.

Some of the following steps may have already been performed. Skip them.

1. Stop the compressor. Do not disconnect the electrical power to the compressor.
2. Disconnect the gas lines from the supply and return couplings of the cold head.
3. Locate two adapter fittings, P/N 255919B2, optional accessories available from SCAI.

NOTE

Omit Step 4 when the cold head has not been removed from the vacuum enclosure.

4. Stand the cold head on a work surface, resting on its valve motor housing.
5. Connect an adapter fitting to the supply (red) coupling on the cold head.
6. Connect another adapter fitting to the return (green) coupling of the cold head.
7. Connect a charge line to the pressure regulator of a helium gas cylinder containing 99.995% pure helium gas with a dew point less than -50° C (-58° F) at 2070 kPa (300 psig). Set the regulator at 690 kPa (100 psig).

 **WARNING**

AVOID INJURY. Never use compressed helium gas from a cylinder without a proper regulator. Overpressure can cause serious injury if the system equipment ruptures. When handling pressurized gas lines and other pressurized equipment, always wear eye protection. Never apply heat to a pressurized gas line or other pressurized components.

8. While connecting the charge line to the adapter fitting installed on the supply coupling of the cold head, thoroughly purge the charge line from the regulator. It is important to remove all air contaminants to prevent them from entering the system.
9. Connect the cold head cable to the cold head. Be sure the other end of the cable is connected to the compressor.
10. Open the vent valve on the adapter fitting installed on the return coupling of the cold head.
11. Open the charge valve on the supply coupling of the cold head.
12. Start the compressor. The cold head valve motor will also run, allowing the gas to circulate through the cold head and discharge through the vent valve.

13. After running 30 to 45 seconds, close off the helium supply with the gas cylinder valve (not the regulator). Watch the regulator pressure gauge. When the pressure falls to 35 to 70 kPa (5 to 10 psig), open the gas cylinder valve to increase the pressure to 690 kPa (100 psig).
14. Repeat Step 13 ten-(10) times.
15. Close the vent valve.
16. With the gas cylinder valve open and the cold head operating, remove the adapter fitting from the cold head return coupling.
17. Press the compressor power switch to stop the compressor and the cold head valve motor.
18. Adjust the gas cylinder regulator to charge the cold head to the system equalization pressure specified for the compressor being used in this system.
19. Close the charge valve on the adapter fitting.
20. Close the gas cylinder valve.
21. Disconnect the charge line from the adapter fitting. Store the charge line to keep it clean.
22. Remove the adapter fittings from the cold head supply and return couplings.
23. Disconnect the cold head cable from the cold head.
24. Reinstall the cold head in the cryopump. Refer to Cold Head Installation into the Cryopump in the System manual.

This completes the procedure for gas cleanup and recharging of the cold head (or cryopump). It is now ready to be connected to the system if the compressor and gas lines do not need to be cleaned. See the Installation section of the System manual.

Gas Cleanup of the Compressor

Refer to Gas Cleanup in the Maintenance section of the Compressor manual.

Leak Check the Refrigeration System

In addition to identifying suspected leaks, check the gas-charged component for helium leaks each time it has undergone any amount of disassembly. Use a helium mass spectrometer leak detector if available. Follow its manufacturer's instructions.

If a leak detector is not available, use a commercial leak detection solution. However, small leaks may not be detected. Also, it is important to:

- fully coat the joint being tested.
- allow time for bubbles to form at a small leak.
- look carefully for the smallest bubble formations.

After solution testing is completed, use water to wash all residues from joints and couplings.

In either method of testing, do not assume that one leak is the only one. Check all joints.

Leak detection by instruments can be misleading. Leaking gas can form patterns that indicate leaks at sound joints. Large leaks or a high gas concentration can make isolation difficult.

Leaks occur most frequently at threaded joints. However, they can occur also at brazed and welded joints.

The flat gasket in the face of the Aeroquip male coupling seals the joint. A leak at this gasket seal can be detected only when a gas line is connected. A leak here can be caused by:

- the coupling not fully tightened.
- a worn, damaged or missing gasket seal.
- dirt on or under the gasket seal.
- dirt on the female coupling's mating surface.
- damaged parts on either coupling which prevent proper mating or sealing.

Figure 19 identifies points at which leaks in a cold head may be detected. A motor housing-to-base or motor base-to-warm flange leak indicates a defective O-ring seal, improperly tightened bolts or dirty mating surfaces. Except when torquing the bolts can stop the leak, correction requires disassembly.

Electrical receptacle flange-to-housing, adapter-to-housing, adapter-to-base, adapter-to-body or variable orifice (not shown in Figure 19) leaks are often corrected by tightening the threaded parts. If tightening is not adequate, disassembly to replace defective parts is required. The electrical receptacle must be replaced if there is leakage at its insulator. Leaks at a gas coupling poppet seat require replacement of the poppet, of the coupling body, or both. None of these items is repairable. Rather than replacing the adapter or coupling body, wrapping their threads with 2 1/2 to 3 turns of Teflon tape and reassembling them may stop the leak. See the procedure in the Gas Lines manual for repairing Aeroquip couplings.

A leak at a weld in the cylinder assembly is possible. Use a leak detector to check for helium at the vacuum pumpout port. Consult a SCAI Service Center if a cylinder weld leak is found.

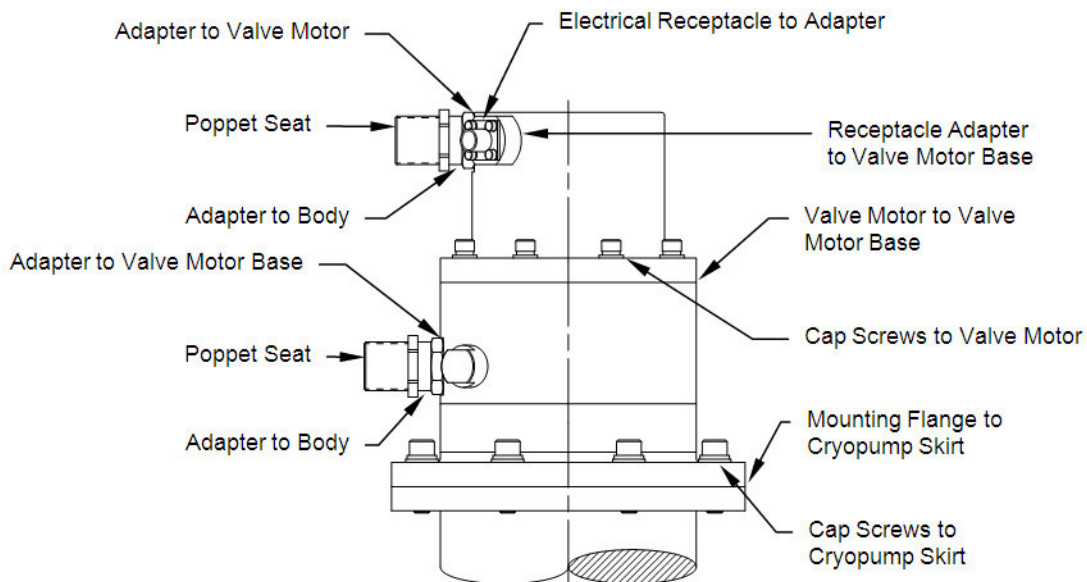

Figure 19 Possible Points of Gas Leaks

Leak Repair

Leaks in the convoluted metal tubing cannot be repaired. Discard the damaged gas line and install a new one.

Leaks at welded joints require special skills to repair. Consult a SCAI Service Center.

Leaks at threaded joints are frequently stopped by tightening the coupling. Continued leakage after tightening requires coupling repair. Install new O-rings or Teflon tape as required.

Leaks at the self-sealing couplings can be repaired by replacing worn or damaged parts.

To repair a coupling, refer to the procedure in the Maintenance section of the Gas Lines manual.

CAUTION

AVOID CONTAMINATION. A leaking coupling on an adsorber should not be repaired in the field. Consult a SCAI Service Center. Venting the adsorber will introduce contaminants to the system that cannot be removed in the field.

(This page is intentionally blank.)

TROUBLESHOOTING

The Troubleshooting Guide that follows lists problems that can occur with the system components and suggests causes and corrective actions.

See additional troubleshooting and testing procedures in the Compressor and Cold head manuals.

WARNING

ELECTRIC SHOCK. Disconnect the power to the compressor before troubleshooting the electrical components.

WARNING

AVOID INJURY FROM BURNS by allowing the compressor to cool for ½ hour after shutdown before removing the cover for maintenance.

WARNING

AVOID ELECTRIC SHOCK. Permit only qualified electrical technicians to open electrical enclosures, to perform electrical checks or to perform tests with the power supply connected and wiring exposed. Failure to observe this warning can result in serious injury or death from electric shock.

CAUTION

PRESERVE YOUR WARRANTY. Modification to equipment without the consent of the manufacturer will void the warranty.

Troubleshooting Guide

<u>Problem</u>	<u>Possible Cause</u>	<u>Corrective Action</u>
Compressor and items powered from it do not start when the start switch on the compressor is closed. Run light is not on.	No electrical power.	Check that the power source is on and the power cord is connected.
	Tripped circuit breaker in the compressor capsule.	Check the voltage. Reset the circuit breaker. Consult a SCAI Service Center if the problem persists.
	Open fuse in the control circuit.	Check for a short circuit. Replace the fuse. Consult a SCAI Service Center if the problem persists.
	Wrong phase sequence.	Interchange any two incoming power leads (except ground) at the power cord plug or at the customer's disconnect switch.

<u>Problem</u>	<u>Possible Cause</u>	<u>Corrective Action</u>
Run light comes on for 30 seconds, then goes off, but the compressor does not start.	Defective motor contactor or open circuit to the motor contactor.	Measure the motor relay coil resistance. See the compressor manual. Check for an open circuit. Replace the coil if it is defective.
Three-phase compressor starts but runs roughly and it does not build significant pressure.	Three-phase motor is running in reverse.	Immediately stop the compressor. Interchange any two incoming power leads (except ground) at the power cord plug or at the customer's disconnect switch.
Compressor starts but shuts down sometime later.	Wrong equalization or operating pressure.	Refer to Specifications in the compressor manual and the section on Charging and Venting in this manual. Leak check the system if the pressure is low.
	Low oil flow.	Look for oil leaks in the compressor capsule. Consult a SCAI Service Center.
	Orifice or the oil cooling line filter is blocked.	Replace the orifice and the filter.
	Insufficient coolant for the compressor.	Check the coolant flow and the temperature. Refer to the Specifications.
	Circuit breaker or fuse is open.	Reset the circuit breaker or replace the fuse. Compare the electric service with the system specifications. Consult a SCAI Service Center if the problem persists.
	Component failure in the power circuit.	Check for an open circuit breaker or fuse. Reset or replace if necessary. Check for a faulty component.
	Compressor water high temperature switch opens.	Check the coolant flow and temperature. Refer to Specifications in the compressor manual.

<u>Problem</u>	<u>Possible Cause</u>	<u>Corrective Action</u>
Compressor starts but shuts down sometime later. (continued)	Incorrect current draw.	Measure the current. Check the motor winding resistances. See the compressor manual. If checks reveal failed motor windings or a locked rotor, consult a SCAI Service Center.
	Compressor overload relay opens.	If water and power checks indicate utilities are within the specifications, interlocks may be faulty. Consult a SCAI Service Center.
System starts, but the gas pressures are abnormally high or low.	Wrong equalization pressure.	Refer to Specifications in the compressor manual and the section on Charging and Venting in this manual. Leak check the system if the pressure is low.
	Gas line couplings are not fully engaged.	Be sure that all Aeroquip couplings are fully engaged and torqued.
	Gas lines are connected wrong.	Reconnect. See the Installation section.
Gradual loss of helium gas pressure.	Gas is leaking from the compressor.	Leak check the compressor and repair.
Compressor runs, but elapsed time meter does not.	Defective elapsed time meter or motor contactor.	Replace the defective component.

 **WARNING**

AVOID INJURY. The compressor's elapsed time meter contains a lithium battery. Do not remove the battery. Do not recharge, disassemble, mutilate, wet or dispose of the meter in fire. Contact local environmental authorities for proper disposal of the lithium battery.

Valve motor does not start when the compressor starts.	Cold head cable is not connected.	Stop the compressor. Connect the cable.
--	-----------------------------------	---

<u>Problem</u>	<u>Possible Cause</u>	<u>Corrective Action</u>
Valve motor does not start when the compressor starts. (continued)	Open circuit in the cold head cable.	Disconnect the cable. Check each conductor for continuity. Replace the cable if necessary.
	Blown fuse in the compressor electrical box.	Check the fuse. Replace if blown. Consult a SCAI Service Center if the problem persists.
Valve motor hums but does not start.	Open circuit in the cold head cable.	Disconnect the cable. Check each conductor for continuity. Replace the cable if necessary.
Valve motor runs, but there is no cooldown.	Loss of insulating vacuum.	Check the vacuum system for operation and leaks.
	Gas lines are connected wrong.	Reconnect. See the Installation section in this manual.
	Gas line couplings are not fully engaged.	Be sure that all Aeroquip couplings are fully engaged and torqued.
	Compressor output is inadequate.	Troubleshoot the compressor. See the compressor manual.
Shroud is sweating or is abnormally cold.	Loss of insulating vacuum.	Check the vacuum system for operation and leaks.
Abnormally noisy operation after a sustained period of five to fifteen minutes.	Incorrect compressor pressures.	Troubleshoot the compressor. See the compressor manual.
	Contaminants in the gas.	Perform the Gas Cleanup and Charging procedure on the cold head, compressor and the gas lines. Refer to their manuals. If the problem remains, consult a SCAI Service Center.
	Mismatch of electric service frequency with frequency on label adjacent to cold head electrical receptacle.	Consult a SCAI Service Center.
Intermittent operation.	Compressor is cycling on and off.	Troubleshoot the compressor. See the compressor manual.

<u>Problem</u>	<u>Possible Cause</u>	<u>Corrective Action</u>
Temperature is cycling.	Contaminated gas is causing a cold head freezing-thawing cycle.	Perform Gas Cleanup and Charging procedure on the cold head (procedure in this manual) and on the compressor and gas lines. See their manuals. If the problem remains, consult a SCAI Service Center.
Sudden loss of refrigeration capacity.	Loss of insulating vacuum.	Check the vacuum system for operation and leaks.
	Compressor malfunction.	Troubleshoot the compressor. See the compressor manual.
Slow loss of refrigeration capacity.	Small insulating vacuum leak.	Leak check and repair the vacuum system.
	Cold head is leaking.	Use the Leak Checking and Leak Repair procedures in this manual.
	Worn seals.	Use the appropriate cold head Disassembly and Repair procedures in the cold head manual. Leaking seals will be confirmed by a streaming pattern of black particles on the displacer near the seal rings.
During rough pumping, pressure in the vacuum enclosure will not fall low enough to maintain an adequate vacuum.	Vacuum chamber leaks.	Leak check the system. Repair the leaks. Refer to the Leak Checking and Leak Repair sections in this manual.
	Outgassing is occurring.	Vacuum bake the vacuum chamber. Refer to the Vacuum Baking sections in this manual.
	Gas permeates the gaskets and joints of the vacuum chamber.	Review the gasket or seal material and joint design. Check that all bolts are tightened.
Cooldown time is excessively long.	Oil contaminates the cryopanel.	Clean the cryopump chamber. Replace the cryopanel. Refer to the Cryopanel section.

<u>Problem</u>	<u>Possible Cause</u>	<u>Corrective Action</u>
Cooldown time is excessively long. (continued)	Loss of refrigeration.	Refer to the Troubleshooting Guides in the compressor and cold head manuals.
	Silicon diode is inoperative.	Refer to Functional Check in the Silicon Diode Maintenance section in this manual.
	High heat load due to heat source, vacuum leaks, and very high initial pressure or helium, hydrogen or neon gases in the system.	Reduce the heat load. Keep the vacuum chamber clean. Shield all heat sources. Interpose a baffle, preferably water-cooled, between any high temperature heat source and the cryopump. Reduce the crossover pressure. Leak check the system. Refer to the Leak Checking and Leak Repair sections in this manual.
	Thermal short.	Look for a cryopanel that touches the enclosure or another cryopanel. Reposition it to leave space between the cryopanel or the vacuum enclosure.
Temperature of the second-stage cryopanel cycles above 20 K.	Loss of refrigeration.	Refer to the Troubleshooting Guides in the compressor manual.
	Excessive gas load in the system.	Reduce the gas load. Leak check the system. Refer to the Leak Checking and Leak Repair section in this manual.
	Cryopanel is overloaded.	Regenerate the cryopump.
Temperature of the second-stage cryopanel slowly increases above 20 K, but the pressure remains below 5×10^{-5} torr.	The cryopump absorbs more radiant heat as it becomes coated with water vapor and other gases.	Shield the cryopump from any high temperature heat sources.

<u>Problem</u>	<u>Possible Cause</u>	<u>Corrective Action</u>
Temperature of the second-stage cryopanel is less than 20 K, but the pressure is above 5×10^{-5} torr.	Incorrectly mounted cryopanel.	Tighten the cryopanel to the heat stations. Check for damaged or missing indium gaskets. Replace the gaskets if necessary.
	Oil contaminates the cryopanel.	Clean the cryopump chamber. Replace the cryopanel. Refer to the Cryopanel section in this manual.
	Corroded cryopanel.	Replace the cryopanel.
Pressure slowly increases, and the second-stage cryopanel temperature increases when the pressure rises above 5×10^{-5} torr.	Hydrogen or helium accumulation causes a heat transfer load by conduction.	Evacuate the chamber to a lower initial pressure. If the problem continues, regenerate the cryopump.
	Oil contaminates the charcoal coating.	Replace the second-stage cryopanel. Refer to Regeneration: Evacuation Phase in the Operation section of this manual.
Cryopump suddenly warms up.	High gas or heat load.	Check the integrity of the vacuum chamber. Check for leaks.
	A thermal short has occurred in the first or second stages.	Regenerate the cryopump. Look for a cryopanel that touches the enclosure or for cold spots on the exterior of the cryopump body. Reposition the cryopanel to leave space between the panel and the enclosure.
	Temperature cycling has caused the charcoal coating to release helium or hydrogen, because the cold head or compressor is inoperative.	Refer to the Troubleshooting Guides in the compressor manual.
	Power interruption.	Regenerate the cryopump.
	Silicon diode is inoperative.	Refer to Silicon Diode in the Maintenance section of this manual.

<u>Problem</u>	<u>Possible Cause</u>	<u>Corrective Action</u>
Cold head does not start or starts and stops intermittently.	Cold head or compressor is inoperative.	Refer to the Troubleshooting Guide in the compressor manual.
	Open circuit in the cold head cable.	Disconnect the cable. Check each conductor for continuity. Replace the cable if necessary.

PARTS

Ordering

The nameplate fastened to the cold head's motor housing identifies the cryopump as follows:

Model Number
Part Number
Serial Number
Date of Manufacture

Furnish this complete information when ordering parts. Also, order parts by part number and name. Refer to the next section for Parts Identification and Numbers.

Parts Identification and Numbers

Parts common to all Marathon[®] CP-20 Cryopumps.

<u>Item</u>	<u>Part Name</u>	<u>Quantity</u>	<u>Part Number</u>
1	O-ring, #2-161, cold head warm flange to vacuum enclosure	1	77328
2	Inlet louver	1	267502D
3	First-stage cryopanel	1	267489D2
4	Second-stage cryopanel service kit Kit includes:		F267626D
	Second-stage cryopanel	1	267626D
	Indium gasket, inlet louver	12	255261B
	Indium gasket, first-stage heat station	1	267270B
	Indium gasket, second-stage heat station	3	267524A
5	Single silicon diode temperature sensor assembly, 4 pin, standard	1	253995C2
6	Relief valve, elbow, including relief valve and	1	262889A3
	O-ring for relief valve seat	1	77213
	O-ring for relief valve body	1	77212

Optional Parts for Marathon[®] CP-20 Cryopumps.

7	Dual silicon diode temperature sensor assembly, 10 pin, for use with a Marathon [®] Cryopump Controller	1	F266686A1
8	Hydrogen vapor bulb temperature sensor, back mount	1	255193C
9	Hydrogen vapor bulb temperature sensor, bottom mount	1	263387C
10	Vent adapter for relief valve (ISO NW 40 port)	1	260936B

(Parts list is continued on the next page.)

<u>Item</u>	<u>Part Name</u>	<u>Quantity</u>	<u>Part Number</u>
11	Rupture disc, 172 kPa (25 psig)	1	260022A2
12	Rupture disc, elbow, 172 kPa (25 psig)	1	262900B1
13	Pumpout/nitrogen purge port/thermocouple gauge port (capped VCR)	1	266682A13
14	Blank for 1.33" O.D. accessory port	1	260021A2
15	O-ring for nitrogen purge port	1	77183
16	Copper gasket for 1.33" accessory port	1	43100
17	O-ring and centering ring for ISO NW 40 relief valve vent adapter port	1	42527
18	O-ring with centering ring for ISO NW 25 pumpout port	1	42518
19	Copper gasket for auxiliary 2.75" CF port	1	43198
20	Plug, 4-socket, for temperature sensor cable for single diode sensor	1	34080
21	Temperature sensor cable assembly, 2.4 m (8 ft.) long, with 4-socket plug, item 20, for single diode sensor	1	262437B1
22	Blanket heater, 500 watts, 208 V~, 190° F thermostat, with mounting springs	1	267553C