



Operation manual

Filament Power Supply

Type: FPS

Serial no:





FERROTEC GmbH

Postfach 33
Seerosenstraße 1
D-72669 Unterensingen

Telefon: +49 (0) 7022 - 9270-0
Telefax: +49 (0) 7022 - 9270-10
Internet: www.ferrotec-europe.com
E-Mail: ebgun@de.ferrotec.com

Version 1.3_13_EN
Translation of the original Operation manual

		NOTICE
	<p><i>This instruction handbook is an integral part of the filament power supply and must be kept readily at hand for the operating personnel at all times.</i></p> <p><i>The safety instructions contained in it must be obeyed.</i></p> <p><i>If the machine is resold, the instruction handbook must always be delivered with it as well.</i></p>	

Liability

The manufacturer's liability for the Filament power supply is based on the principles of German law.

The manufacturer accepts no liability for damage and losses due to:

- improper use;
- operation by unauthorised personnel;
- failure to follow safety regulations;
- failure to heed the information in the instruction handbook.

Translation

If the machine is sold to a country in the EEA, this instruction handbook must be translated into the language of the country in which the machine is to be used.

Should the translated text be unclear, the original instruction handbook (German) must be consulted or the manufacturer contacted for clarification.

Copyright

No part of this publication may be reproduced, transmitted, sold or disclosed without prior permission. Damages will be claimed for violations.

All rights reserved.

1 Table of Content

1.1 Table of content

1	<i>Table of Content</i>	2
1.1	<i>Table of content</i>	2
1.2	<i>Table of pictures</i>	3
1.3	<i>Manufacturer's Declaration</i>	4
2	<i>Overview and Intended Use</i>	6
2.1	<i>Overview FPS - System</i>	6
2.2	<i>Intended Use</i>	7
2.3	<i>Explanation of terms</i>	8
2.4	<i>Technical specifications</i>	9
2.4.1	<i>Dimensions and weight</i>	9
2.4.2	<i>Specifications</i>	9
2.4.3	<i>General specifications</i>	9
3	<i>Safety</i>	10
3.1	<i>Notes/Explanations</i>	10
3.1.1	<i>Explanation of used safety symbols</i>	11
3.1.2	<i>Machine identification</i>	12
3.2	<i>Integrated Safety System</i>	12
3.3	<i>Overview of electrical connections</i>	15
3.4	<i>Safety Precautions (by the Operator)</i>	16
3.5	<i>Responsibilities of the operator</i>	17
3.6	<i>Safety inspections and Tests</i>	20
4	<i>General Warnings</i>	21
4.1	<i>Dangers</i>	21
4.2	<i>Operating Areas and Danger Zones at the Machines</i>	22
4.3	<i>Operation and Maintenance Personell</i>	23
4.4	<i>Spare and Wearing Parts</i>	24
4.5	<i>Shutdown Procedure</i>	25
5	<i>Installation</i>	26
5.1	<i>Delivery package</i>	26
5.2	<i>Transport and Packaging</i>	27

5.2.1	<i>Delivery (also for Spare and replacement parts)</i>	27
5.3	<i>Intermediate Storage</i>	28
5.4	<i>Transportation to the point of Installation (by Operator)</i>	28
5.5	<i>Assembly, Installation (only for trained personel)</i>	29
5.5.1	<i>Assembly</i>	29
5.5.2	<i>Elecric Connection</i>	29
5.5.3	<i>Connecting the filament power supply</i>	32
6	<i>Operation</i>	34
6.1	<i>Operation and display elements</i>	34
6.2	<i>Putting in operation fort he first time (for specialized personnel only)</i>	35
6.3	<i>Operation modes</i>	36
7	<i>Cleaning/Maintenance</i>	37
7.1	<i>Complete Daily Cleaning</i>	38
7.1.1	<i>Maintenance</i>	38
7.1.2	<i>Function test plan</i>	39
7.1.3	<i>Inspections</i>	39
8	<i>Troubleshooting</i>	40
9	<i>Emergency</i>	41
10	<i>Dismantling/Disposal</i>	41

1.2 Table of pictures

<i>Fig. 2-1</i>	<i>Overview FPS-System</i>	6
<i>Fig. 3-1</i>	<i>Electrical connections</i>	15
<i>Fig. 5-1</i>	<i>Delivery package</i>	26
<i>Fig. 5-2</i>	<i>Wiring diagram of the CARRERA-System</i>	31
<i>Fig. 5-3</i>	<i>Overview of the electrical connectors</i>	31
<i>Fig. 6-1</i>	<i>Overview of operation and display elements</i>	34

1.3 Manufacturer's Declaration

FERROTEC GmbH
 Seerosenstrasse 1
 72669 Unterensingen

Manufacturer's Declaration

pursuant to

- **The EC Low Voltage Directive 2006/95/EG**
- **The EMC Directive EMV 2004/108/EG**

We hereby declare that the design of the

Description: Filament Power Supply

Type: FPS

as delivered complies with the above regulations and following DIN EN standards.

Harmonised standards pursuant to the directives:

Directive / Norm	Title	Version	Comment
2006/95/EG	EC- Low Voltage Directive	2006	
DIN EN 62079 :2001	Preparation of instructions - Structuring, content and presentation	2001	Harmonised standard
DIN EN 60204-1 :2006	Safety of machinery; Electrical equipment of machinery – Part 1: General Requirements	06.11.2007	Harmonised standard
DIN EN 60204-11 :2000	Safety of machinery Electrical equipment of machinery — Part 11: Requirements for high voltage equipment for voltages above 1000 V alternating current or 1500 V direct current but not above 36 kV	27.11.2001	Harmonised standard
2004/108/EG	EC Directive: EMC	2004	

Unauthorised changes to the machine invalidate this declaration.

Operation of this machine is forbidden until the complete plant is found to be in conformity with the regulations of all relevant, applicable EC directives.

Unterensingen, 6/ September 2010

.....
Signature
Title / Name / Position

Authorised person for the technical documentation:

Mr. Alfred Mutscheller
Produktmanager EB Evaporator
FERROTEC GmbH
Seerosenstrasse 1
72669 Unterensingen

2 Overview and Intended Use

2.1 Overview FPS - System

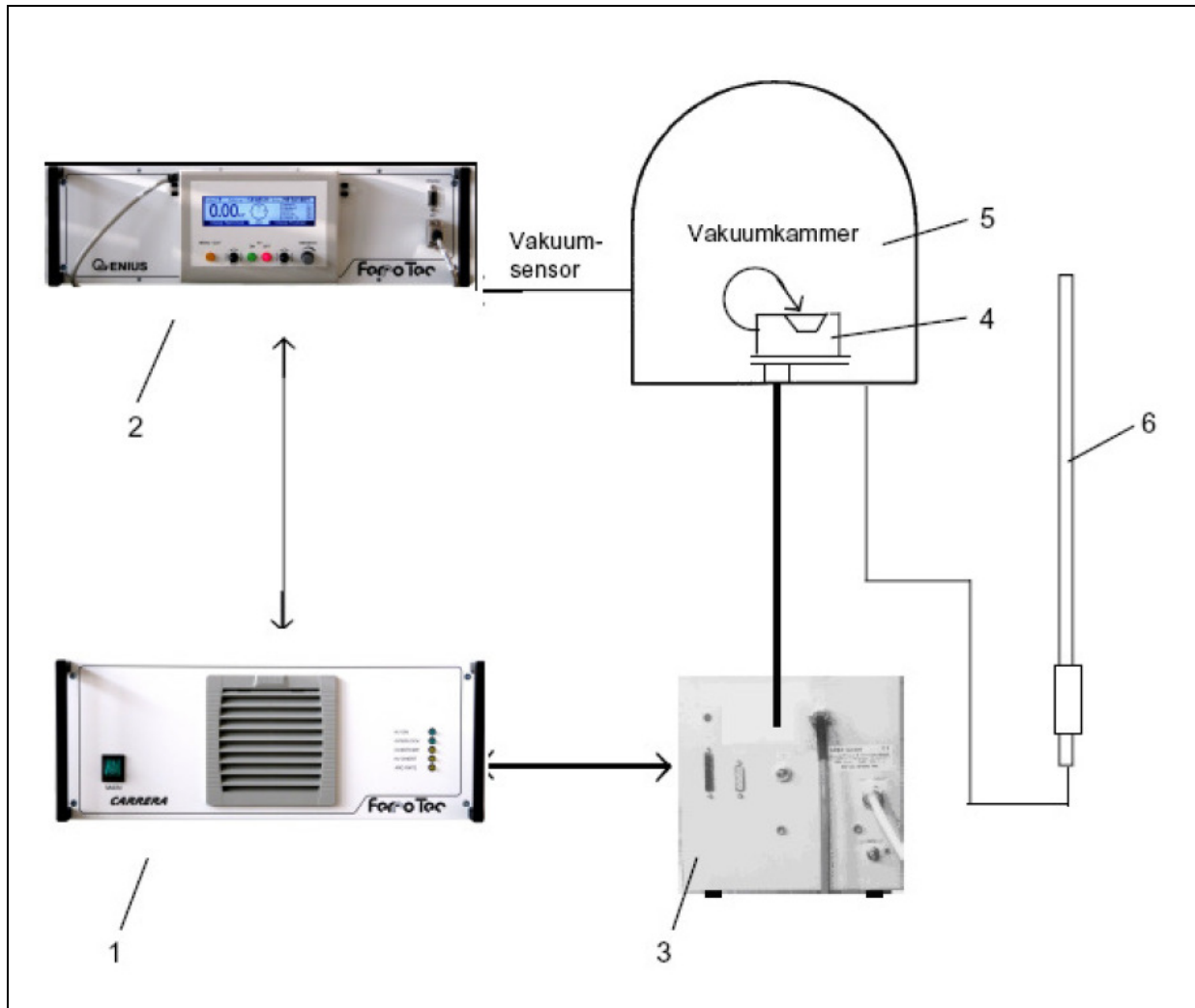

Fig. 2-1 Overview FPS-System

The complete evaporator package consist of the following:

- 1 High voltage power supply HVP
- 2 Electron beam evaporator controler GENIUS with hand remote control
- 3 Filament power supply (FPS)
- 4 Electron beam evaporator
- 5 Vacuum chamber
- 6 Grounding rod

2.2 Intended Use

The filament power supply FPS is part of a group of devices for the operation of an electron beam evaporator installed in a vacuum chamber..

The group of devices consists of:



- High voltage power supply (HVP)
- Electron beam evaporator controller GENIUS with integrated remote control
- Filament power supply (FPS)
- Grounding rod

Use of the filament power supply for any other purpose requires the approval of the manufacturer.



The filament power supply HVP generates a heating current for a filament needed to emit electrons to operate an electron beam evaporator. Other fields of application are only permitted with the written authorization of the manufacturer.



This operating manual deals solely with the design and operation of the filament power supply. Please see the relevant operating manuals for operation of the other devices in the group (see table of contents and figures, appendices 1 + 2).

These devices were developed, designed and built solely for commercial/industrial use.

	 DANGER
	<p><i>The filament power supply FPS is intended solely for the purpose described above. Any other use or modification of the filament power supply FPS without the written consent of the manufacturer is deemed improper. The manufacturer accepts no liability for resultant damage. The risk is borne solely by the operator.</i></p> <p><i>The high filament power supply FPS may only be put into operation when it has been ensured that all safety equipment is operative and the total installation of the vacuum system comply with EU directives.</i></p>

Proper use of the machine in accordance with its intended use includes compliance with the manufacturer's operating, maintenance and repair instructions. The use is restricted to rooms in a building or halls.

		NOTICE
	<p>Notice on application of the EMC Directive 2004/108/EC in the manufacturer's declaration: <i>The filament power supply FPS is only allowed to be operated in Industrial environment.</i></p>	

		NOTICE
	<p><i>The filament power supply FPS is an option of the high voltage power supply HVP.</i></p>	

The instructions given in the operation manual of the filament power supply FPS have to be followed. .

2.3 Explanation of terms

- HVP - High voltage power supply unit
- GENIUS - Electron beam evaporation controller
- FPS - Filament Power Supply

2.4 Technical specifications

2.4.1 Dimensions and weight

Width:	235 mm
Height:	235 mm
Depth:	330 mm
Weight:	approx.. 19,3 kg

2.4.2 Specifications



Power:	0,5 kW
Mains power supply:	1 x 230 V
Frequency:	50/60 Hz
Cathode voltage:	10 V, AC 50 A



2.4.3 General specifications



Ambient temperature :	
Lower limit:	-10 bis 35 °C
Upper limit :	+ 40° C
Air humidity max:	65 %
Noise level:	L _{PA} = < 70 dB (A)



3 Safety



3.1 Notes/Explanations



		DANGER
	<p><i>“DANGER” warns of dangerous situations. Avoid these dangerous situations! Otherwise they could result in severe injury or death.</i></p>	

		WARNING
	<p><i>“WARNING” warns of dangerous situations. Avoid these dangerous situations! Otherwise they could result in severe injury or death.</i></p>	















		CAUTION
	<p><i>“CAUTION” in connection with this warning symbol warns of dangerous situations. Avoid these dangerous situations! Otherwise they could result in severe injury or death.</i></p>	

		NOTICE
	<p><i>“NOTICE” gives you recommendations for action, and there is no risk of injury if you fail to comply with them. However, follow these recommendations for action to avoid damage and annoyance.</i></p>	

		NOTICE
	<p>Instruction manual mandatory; <i>framed and marked with a book symbol.</i></p>	

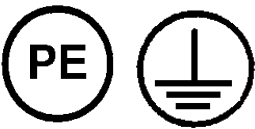
		NOTICE
	<p>„NOTICE“ are marked with the word "NOTICE" . This informs you about further literature.</p>	

3.1.1 Explanation of used safety symbols

	 <p style="text-align: center;">DANGER</p> <p>Danger from electric current framed and marked with the symbol shown opposite.</p>
	 <p style="text-align: center;">DANGER</p> <p>Danger of burns framed and marked with the symbol shown opposite.</p>
	 <p style="text-align: center;">DANGER</p> <p>Danger of your hands being crushed or injured framed and marked with the symbol shown opposite.</p>
	 <p style="text-align: center;">DANGER</p> <p>Danger from magnetism framed and marked with the symbol shown opposite.</p>
	 <p style="text-align: center;">DANGER</p> <p><i>Danger for people with cardiac pacemakers (and with insulin pumps and people with active or passive prostheses and ferromagnetic or conductive foreign bodies) are marked with the symbol shown opposite.</i></p>
	 <p style="text-align: center;">NOTICE</p> <p>Protective conductor connection marked at the connection points by the symbol shown opposite.</p>
	 <p style="text-align: center;">NOTICE</p> <p>Environment sign marks actions to protect the environment.</p>

3.1.2 Machine identification

Serial-Number



The information in this instruction handbook only applies to the Filament power supply whose type designations are given on the title page

The identification plate including the serial number is attached on the back of the filament power supply

It is important that the type designation and the serial number is stated correctly when consulting us.

We can only process your query properly and quickly if this information is correct.



3.2 Integrated Safety System

		NOTICE
	<p><i>The filament power supply is intended for use in combined equipment with electron beam evaporators, and the safety systems have been designed accordingly. If this device is operated outside this equipment combination then the approval of Messrs. FERROTEC GmbH must be obtained.</i></p>	

The filament power supply is equipped with :

- **connectors plugs** that have been designed to be **impossible to connect incorrectly**.

The filament power supply is connected via a 2-pin plug (230 V, **N that can withstand current and mid-point conductor PE with GREEN/YELLOW cable sheath**).

		DANGER
	<p><i>The filament power supply is operated at a potentially lethal high voltage. It is strictly forbidden to disable or deactivate the safety devices.</i></p> <p><i>Such an action can result in damage to the equipment and personal injury.</i></p>	

The integrated safety systems must be checked at regular intervals (**d**= daily, **w** = weekly, **m** = monthly, $\frac{1}{2}$ **y** = half-yearly, **y** = yearly).

The test methods that are to be applied are:

V = visual inspection, **F** = function test, **M** = measurement.

The operator must implement the following in the overall plant:

Mains Isolator (Main Switch)

The filament power supply is connected to the main power supply system.

Test	
Interval	Method
y	F

The filament power supply is connected to and disconnected from the power supply with the main switch for this power supply system

		DANGER
	<p><i>When the main switch is switched off for cleaning, maintenance and repair work, it must be locked with a padlock to prevent unauthorised switching on.</i></p>	

Emergency Stop System



The filament power supply has to be integrated in a master emergency stop system that immediately puts the filament power supply into a safe operating state when actuated.



Test	
Interval	Method
m	F



		DANGER
	<p><i>The owner is required to ensure that that unauthorized persons (i.e., who are not operating or maintenance personnel) are prevented from entering the operating area.</i></p>	

		DANGER
	<p><i>The switch cabinets can only be opened with a special key. Only authorised personnel may have access to the special key. Please ensure that the doors are only opened by suitably competent personnel for maintenance and troubleshooting work and that they are otherwise kept locked!</i></p>	

The operating and maintenance personnel are trained in the use of the machine at its point of installation by personnel from FERROTEC GmbH. Should you have any questions or be uncertain about anything, please contact FERROTEC GmbH.

		NOTICE
	<p><i>It is strictly forbidden to render any of the safety systems inoperative or to modify their action.</i></p>	

		NOTICE
	<p><i>This instruction handbook is an integral part of the filament power supply r and must be kept readily at hand for the operating personnel at all times. The safety instructions contained in it must be obeyed.. If the filament power supply is resold, the instruction handbook must always be delivered with it as well.</i></p>	

		NOTICE
	<p><i>The type, scope and action of the safety systems were arranged with the operator.</i></p>	

3.3 Overview of electrical connections

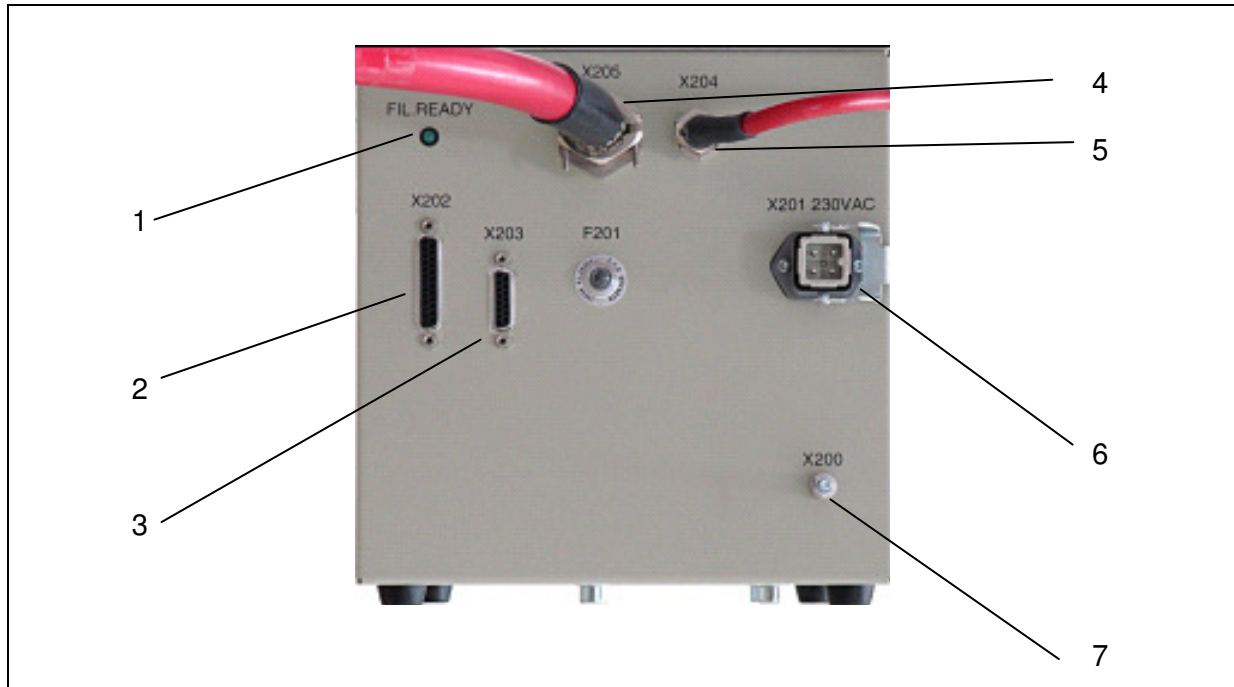

Fig. 3-1 Electrical connections

On the filament power supply there are the following connections:

- 1 LED-Display
- 2 Control cable X202
- 3 Service-Plug X203
- 4 High voltage output X205
- 5 High voltage input X204
- 6 Mains connector X201
- 7 Grounding

3.4 Safety Precautions (by the Operator)

The operator must:

- instruct his operating and maintenance personnel in the use of the **safeguards** of the filament power supply and
- ensure the safety precautions are being observed including the use of personal protective equipment.
- The owner must ensure that entry to the hazard area of the machine (into which the filament power supply has been built) by unauthorized persons (no operating and maintenance personnel) is prevented.

This instruction handbook must be kept in a safe place for future reference. The frequency of inspections and checks must be observed.

The work described in this instruction handbook is explained in such a way that

- the chapters on operation and modes of operation can be understood by an **instructed person** and
- those on transport, installation and assembly, maintenance and troubleshooting by a **skilled person**.

The chapters on **transport, installation and assembly, maintenance and troubleshooting** are intended for **skilled persons only**. Work described in these chapters may only be carried out by such skilled persons.

Instructed Person



A person familiarised with and, if applicable, trained in his or her particular duties by a skilled person and advised of the risks of improper conduct and about the necessary safeguards and safety precautions.

Skilled Person

A person with relevant technical training, know-how, experience and knowledge of applicable standards to enable him or her to assess the work assigned to him or her and to perceive potential risks.

Definitions based on EN 60204-1:2006

3.5 Responsibilities of the operator

		NOTICE
	<p><i>In the EEA (European Economic Area) national implementation of the framework directive 89/391/EEC and corresponding individual directives, in particular the directive 2009/104/EEC concerning the minimum safety and health requirements for the use of work equipment by workers at work, as amended, are to be observed and adhered to. In Germany the Plant Safety Ordinance of October 2002 must be observed (translation of the above-mentioned directive into national law).</i></p>	

The operator must (where necessary) obtain any local **operating permits** required and observe the provisions contained therein

In addition to this he must observe local laws and regulations on

- personnel safety (accident prevention regulations)
- safety of work materials and tools (safety equipment and maintenance)
- disposal of products (laws on wastes)
- disposal of materials (laws on wastes)
- cleaning (cleaning agents and disposal)
- environmental protection.

In addition, the owner must note:

- A constant hazard evaluation of the workplaces (danger of hands being crushed, danger of stumbling) is to be carried out. The measures are to be defined in work instructions and the working personnel are to be instructed accordingly
- The supervisors must check compliance with the measures stated in the work instructions.
- Ensure that the operating personnel are suitably trained.
- Work on electrical equipment is only to be carried out by suitably trained persons. The connecting cables and terminals must be properly insulated and covered.
- It is only possible to ensure optimal functioning of the elements if the machine controller is working perfectly. The switching states of the limit switches must be properly incorporated into the machine controller and the signal cables must be in perfect condition.



- The switching and safety facilities for setting up, testing, shutting down (including shutting down in an emergency), operation, maintenance, cleaning and servicing are to be installed and verified by the person setting up the entire unit. This includes also lockable main switches and emergency shut off switches
- The owner must ensure that the operating stations are not affected by waste gases (such as diesel engine exhaust fumes) or a lack of oxygen.
- The workplaces are to be assessed by the owner in accordance with the noise and vibration regulations. Any noisy areas are to be marked, the employees are to be instructed about them and must use hearing protection.
- The owner is required to provide suitable safety measures for protection against fire such as suitable fire extinguishers of the stipulated number and size at easily accessible points and is to instruct his employees about protection against fire
- The warning notes from the documentation for modules supplied by other companies are to be complied with and integrated into the workplace-related hazard evaluations
- The operator is required to ensure that the filament power supply is only operated when it is in perfect working order

Connections:

Before starting the filament power supply the operator must ensure that:

Only specifically trained personnel are used for installation and start-up if this work is done by the operator himself and that local rules and laws are followed in the way this is installed.

		NOTICE
	<p>Lighting <i>The operator must ensure that there is adequate and uniform lighting in all areas of use of the electron beam evaporator. The recommended illumination is 300 Lux (maintenance value; ASR 7/3 applies in Germany).</i></p>	

		NOTICE
	<p>The owner envisages only one earth circuit connector on the floor of the vacuum chamber. All the devices (Carrera, GENIUS, FPS, and grounding rod) are to be connected in star form from this earthing point. Use the grounding points that have been provided at the individual devices for this purpose. The earth circuit connector itself must be earthed at the earthing point of the building.</p> <p>The guarantee is null and void if the installation is not carried out correctly.</p>	

3.6 Safety inspections and Tests

Factory inspections and tests by the manufacturer.

1. Airborne noise measurement
 - According to the Machinery Directive (Position 1.7.4/f)

2. Tests and inspections in terms of DIN EN 60204-1 (Edition 2007)
 - Check whether the electrical equipment corresponds to the technical documentation (chap. 18.1)

 - Continuous connection of the protective conductor system (chap. 18.2)

 - Insulation resistance tests (chap. 18.3)

 - Voltage tests (chap. 18.4)

 - Protection against residual voltage (chap. 18.5)

 - Function tests (chap. 18.6)

The functions of the electrical equipment, particularly those concerning safety and protective measures, were tested

4 General Warnings

4.1 Dangers

The safety systems and safety instructions described in this handbook must be heeded accordingly.
 The machine is operated from the control unit in combination with the GENIUS controller, the CARRERA high voltage power supply and the overall plant.

The danger zone of the filament power supply is the immediate area around the filament power supply and the vacuum system in which the filament power supply is integrated.

		NOTICE
	<p><i>The operator must ensure that the danger zone around the machine is free of object so that there is no limitation for the access to the filament power supply.</i></p>	



		DANGER
	<p><i>Pay attention to the danger of electric shock when carrying out adjustment, maintenance and repair work! Before touching the electron beam evaporator, discharge it with the grounding rod.</i></p>	

 		DANGER
	<p><i>Pay attention to the dangers from magnetism when using and handling the electron beam evaporator.</i></p> <p><i>People with cardiac pacemakers (and with insulin pumps and people with active or passive prostheses and ferromagnetic or conductive foreign bodies) must keep clear of the electron beam evaporator! The limits of how close they may approach the machine must be clearly marked.</i></p>	

4.2 Operating Areas and Danger Zones at the Machines

The **operating area** is defined by the operator (overall plant).

The **danger zone** during adjustment and maintenance work is the immediate area around the filament power supply.

		WARNING
	<p><i>The danger zone during adjustment, maintenance and repair work extends 1 m around the filament power supply. The area needed to open the switch cabinet doors must be taken into account.</i></p> <p><i>Keep the danger zone around the machine free of objects. Lay cables in such a way that they cannot be tripped over!</i></p> <p><i>The operator must ensure that access to the danger zones by unauthorised persons is prevented..</i></p>	

The danger zones may only be entered for cleaning, maintenance and repair work by skilled personnel under compliance with applicable safety regulations.



4.3 Operation and Maintenance Personell

The operating and maintenance personnel are those people responsible for the transport, assembly, installation, operation, adjustment and cleaning of the machine as well as for troubleshooting.





1. The machine may only be operated by trained and authorised personnel.
2. The different responsibilities in the operation of the machine must be clearly defined and observed so that no confusion with respect to responsibilities arises, thus endangering safety.
3. Whenever any work (operation, maintenance, repair, etc.) is carried out, the shutdown procedure specified in this instruction handbook must be followed.
4. The operating personnel may not apply any working methods that impair the safety of the machine.
5. The operating personnel are co-responsible for ensuring that no unauthorised person works with or on the machine
6. The operating personnel must immediately report any changes in the machine that impair its safety to the responsible executive.
7. The unit may only be operated when it is in perfect working order.
8. The operating personnel are to be equipped by the owner with safety equipment as required by law and appropriate for the materials being processed.
9. The owner is required to regularly check that the personal safety equipment is actually being used.

4.4 Spare and Wearing Parts

Spare parts and accessories that have not been supplied by us have also not been tested and approved by us. The fitting and/or use of such products could therefore negatively affect the design characteristics of your machine. FERROTEC GmbH accepts no liability for damages arising from the use of non-original parts and non-original accessories.

		DANGER
	<p><i>Fundamentally speaking, it is forbidden to make any repairs within the unit.</i></p> <p><i>Danger: high voltages!</i></p>	

4.5 Shutdown Procedure

	<div style="background-color: #0056b3; color: white; padding: 5px; text-align: center;">NOTICE</div> <p>The shutdown procedure may only be initiated by skilled personnel according to the definition in DIN EN 60 204 (see also chap. 3.3).</p>
   	<div style="background-color: #ff0000; color: white; padding: 5px; text-align: center;">DANGER</div> <p>The following procedure for switching off is to be followed without fail before carrying out any cleaning, repair or maintenance work.</p> <ol style="list-style-type: none"> 1. Switch off the unit: <ul style="list-style-type: none"> - Switch off the high voltage with the HV button at the GENIUS. - Turn off the On/Off switch at the HVP high-voltage mains device. - Pull out the mains plugs at the high-voltage mains device X301, control X101 and the filament current supply X201. - Wait for at least 3 minutes before starting work on the electrical equipment. The capacitors must discharge themselves. 2. For maintenance and repair work: <ul style="list-style-type: none"> - Ensure that nothing is still electrically live, - Use an earthing rod to earth all the high-voltage feedthroughs. <p>There is a danger to life and limb for the personnel if this procedure is not followed.</p>

5 Installation

5.1 Delivery package

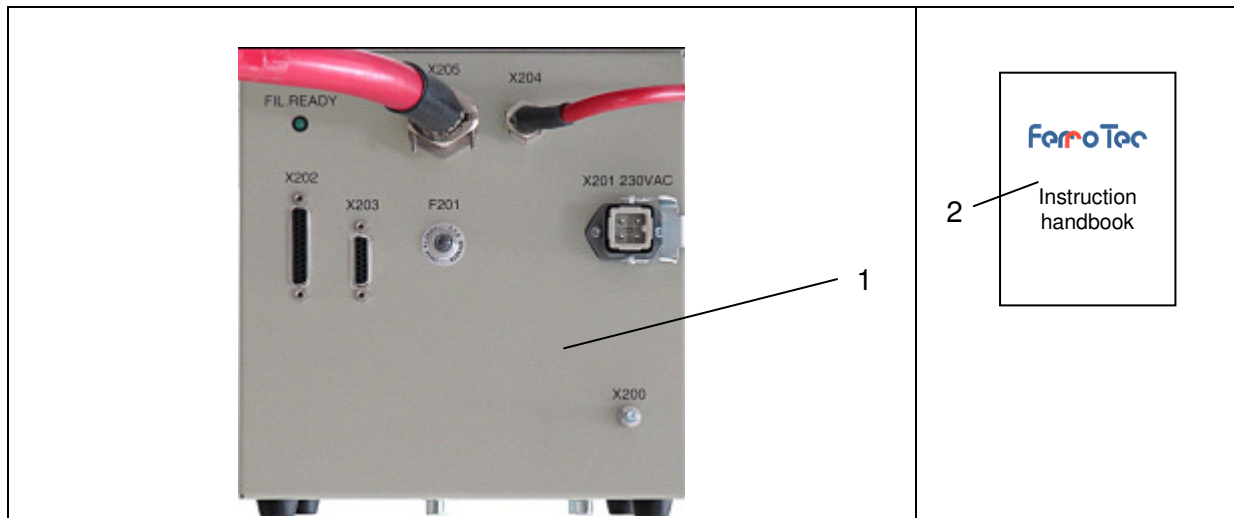



Fig. 5-1 Delivery package

The delivery package consists of:

- 1 Filament power supply FPS
- 2 Instruction handbook
- 3 Mains connecting cable (see Fig. 5-2) Nr. 950024
- 4 High voltage cable: HV-Input (see Fig. 5-2)
P/N. 950004
- 5 High voltage cable to supply filament (see Fig. 5-2)
P/N. 950006
- 6 Grounding cable (see Fig. 5-2) P/N. 950000
- 7 Filament control cable (see Fig. 5-2) P/N. 950013

5.2 Transport and Packaging

Machines, devices and other equipment from FERROTEC GmbH are carefully inspected and packed before shipment. Nevertheless, it is still possible that they might become damaged during transit

		NOTICE
	<p><i>The packaging material is to be suitable to meet the requirements for safe transport of the filament power supply. It is therefore recommended that you keep the packaging material for a possible move of the filament power supply or if it needs to be sent in for maintenance purposes.</i></p>	

5.2.1 Delivery (also for Spare and replacement parts)

Receiving Inspection:

- Check the shipment against the packing list to ensure that it is complete!

If the Packaging is Damaged

- Check the shipment itself for damage (visual inspection)!

Complaints

If the shipment was damaged during transit:

- Immediately contact the last carrier!
- Keep the packaging material (for possible inspection or return shipment)

Packaging for return shipment

Use the original packaging material as far as possible.

If it is no longer available:

- Use the services of a packaging company with suitably competent personnel.
- If you have any questions on packing and transport, please contact FERROTEC GmbH.

		NOTICE
	<p><i>We wish to point out that the device can only be shipped back in the original packing material.</i></p>	

5.3 Intermediate Storage

The freight packaging of the filament power supply and spare and replacement parts is designed for a storage period of three months from delivery.

Storage Conditions

Closed and dry room with a room temperature of +5 °C to +40 °C. The relative humidity allowed is max 80% (not condensing).

5.4 Transportation to the point of Installation (by Operator)



After unpacking of the filament power supply, transport it to the intended place of installation

		NOTICE
	<p><i>The weight of the filament power supply is approx. 19,3 kg.</i></p>	

5.5 Assembly, Installation (only for trained personel)

Assembly and initial start-up must be carried out by skilled personnel from FERROTEC GmbH or the customer's skilled personnel who have been especially trained for this work.

Consult the instruction handbook and technical reference material supplied for assembly and installation of the filament power supply.

		DANGER
	<i>The electrical installation of the filament power supply must be carried out only by trained, skilled personnel.</i>	



5.5.1 Assembly

The filament power supply is designed to be positioned beneath the vacuum chamber on the ground floor. Pay attention and avoid any possible water from the cooling channel or from condensation to drop onto the filament power supply.



5.5.2 Elecric Connection

Connection conditions

- Use exclusively the supplied connection cable for the connection of the filament power supply.
- Observe the prescribed safety earthing connections. . If necessary, the cable should be shortened (do not create loops)
- Make sure there is a differential current switch.
- Connect the filament power supply to the emergency switching system of the whole equipment.

		DANGER
	<p><i>Please, note that before the connection of the filament power supply unit the complete cabling of the vacuum system, the electron beam vaporizer, the high voltage power supply and the Genius control unit must be installed.</i></p>	

Wiring diagram (with an electron beam vaporizer) and the GENIUS control unit.

		NOTICE
	<p><i>On special versions the wiring diagram attached in the Appendix is valid in these case of these designs.</i></p> <p><i>If the filament power supply unit is used the wiring diagram shown in this operation manual is valid.</i></p>	

The wiring diagram contains all connections. The plugs are marked with X...; you will find this marking on the devices as well. The marking of the cables is 95 At the same time these are part numbers for ordering spare parts.

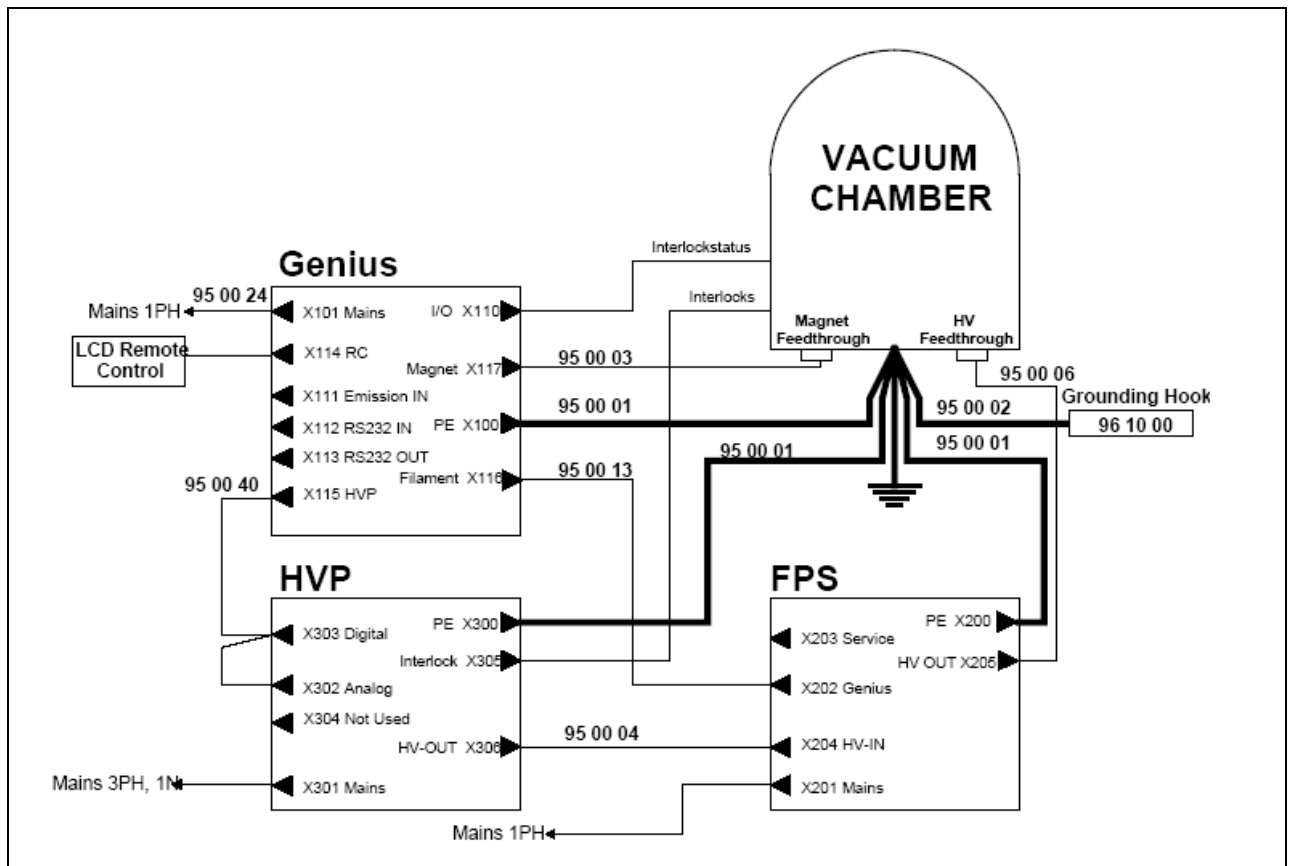

Fig. 5-2 Wiring diagram of the CARRERA-System

Overview of electrical connection

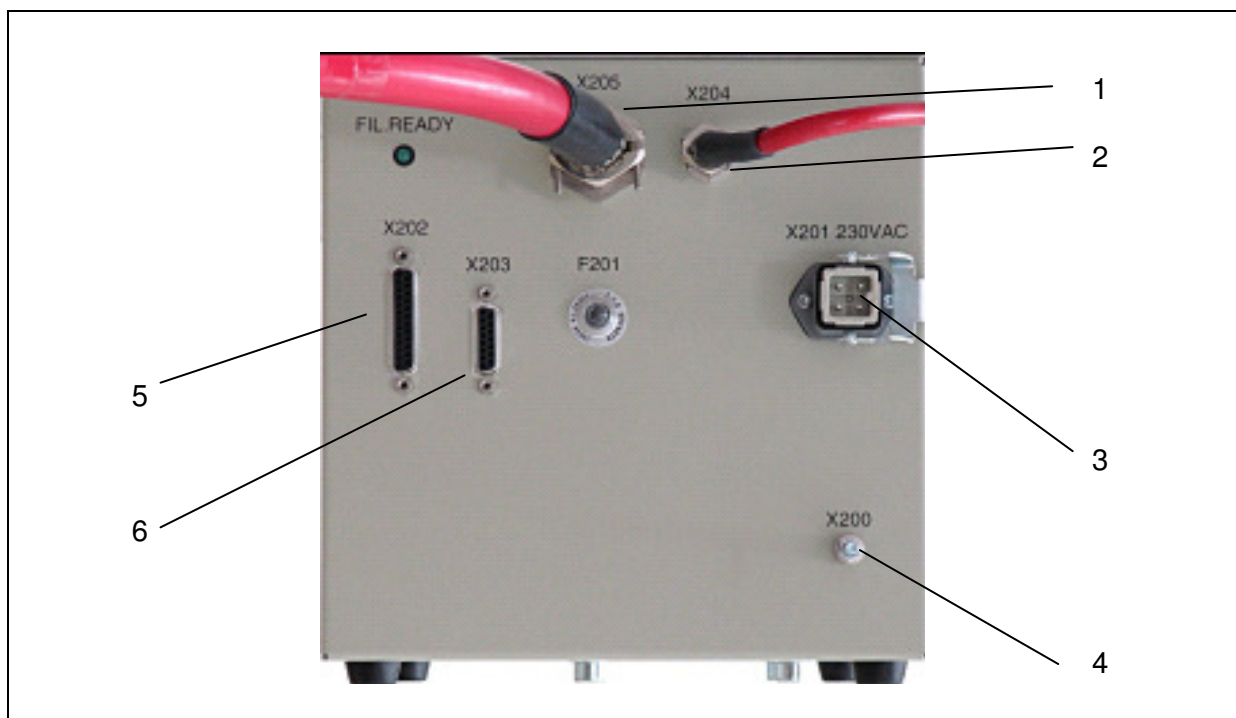

Fig. 5-3 Overview of the electrical connectors

The electric connectors are situated on the rear panel of the filament power supply.

1 HV-output cable **X205**

The cables are pre-confectioned in such a way that they are suitable for FerroTec high-voltage bushings.

2 HV-input cable **X204**



3 Mains connection **X201**

Connection between the power supply and the filament power supply

4 Earthing screw **X200**

5 Filament control cable **X202**

6 Service-connector **X203** (for servicing personnel)

		NOTICE
	<p><i>The filament power supply is used to supply the cathode of the electron beam vaporizer and this is why it is under high voltage.</i></p> <p><i>Operating the filament power supply in the open condition is forbidden as the operator is not protected sufficiently by the housing</i></p>	

5.5.3 Connecting the filament power supply

Connect the filament power supply in accordance with the assembly schematic.

Elements to be connected:

- Earthing line
- Control line
- Line to the high-voltage unit
- Line to the filament
- Mains line

Earthing line

1. Connect the earthing contact **X200** of the filament power supply.
 - For this purpose use a cable with cable lugs, green/yellow wire sheathing and the cross-section of 16 mm².

Control Line



The control line / high-voltage lines establish the connection of the filament power supply with individual devices.



2. Connect the devices in accordance with the overview of electric connections, Fig. 5-3 and the Fig. 5-2 the wiring diagram of the CARRERA system.

Mains supply line

The mains supply line is used to connect the filament power supply to the mains.

3. Connect the plug of the mains supply line to the power connector of the mains power supply plug (Pos. 3).

		NOTICE
	<p><i>The connectors are protected against being confused, i.e. each connector can only be connected to its dedicated socket</i></p>	

		NOTICE
	<p><i>The connecting cables are part of the delivery of filament power supply.</i></p>	

6 Operation

		WARNING
	<p><i>The filament power supply can only be operated by trained personnel.</i></p>	

6.1 Operation and display elements

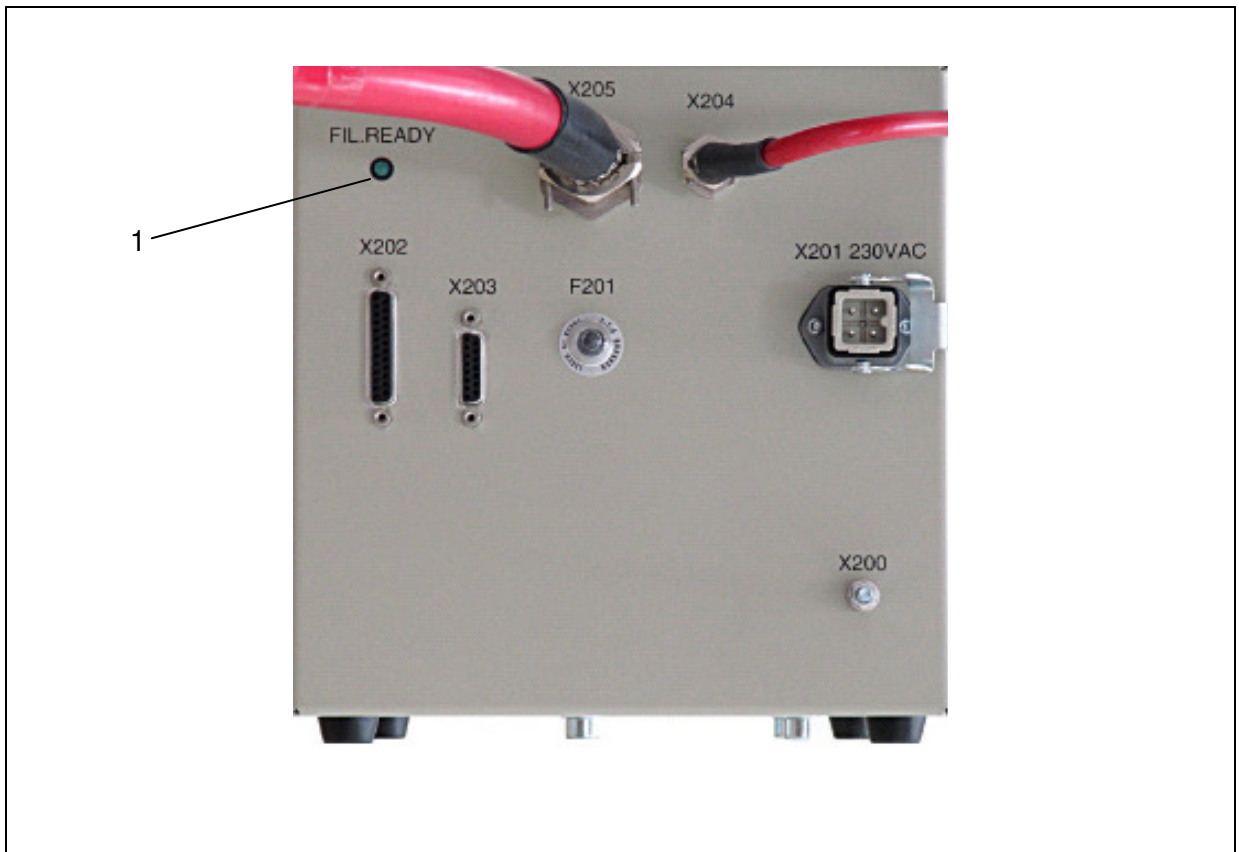



Fig. 6-1 Overview of operation and display elements

- 1 LED-indicator
The indicator is lit when the filament power supply is on.

6.2 Putting in operation for the first time (for specialized personnel only)

		NOTICE
	<p><i>The equipment may only be put in operation by trained specialized personnel.</i></p>	

The filament power supply is put in operation together with the whole system.

The components of the complete system

- Filament power supply (FPS)
- High-voltage power supply unit (CARRERA/HVP)
- Control unit (GENIUS)
- Vacuum system
- Electron beam vaporizer

must be completely installed and connected before the system is first put in operation.

Führen Sie im Rahmen der Erstinbetriebnahme folgende Prüfungen durch:



To put the system in operation carry out the following tests:

1. Check



- the earthing connection;
 - the mains supply line;
 - the control lines;
 - the high voltage cable;
- for correct and tight connection.

2. Test the safety circuit.



3. Test the system of the emergency switch.

		NOTICE
	<p><i>Carry out the relevant tests in compliance with 60 204, item 20. Before carrying out the work, remove the plug to avoid any damage to the electronics.</i></p> <p><i>The earthing cables must be laid directly and made as short as possible, coils of earthing cable can lead to problems and are therefore forbidden.</i></p>	

6.3 Operation modes

		NOTICE
	<i>The operating modes are described in the separate operating instructions of the components of the operating system.</i>	



7 Cleaning/Maintenance

		DANGER
	<p><i>The chapter Cleaning / Maintenance is intended for skilled personnel only. Maintenance, cleaning and repair work may only be carried out by skilled personnel.</i></p>	



Skilled Person

A person with relevant technical training, know-how, experience and knowledge of applicable standards to enable him or her to assess the work assigned to him or her and to perceive potential risks.



The above definition is based on EN 60204-1.

		DANGER
	<p><i>The operating and maintenance personnel are trained in the use of the filament power supply at its point of installation by personnel from FERROTEC GmbH.</i></p> <p><i>Should you have any questions or be uncertain about anything, please contact FERROTEC GmbH.</i></p>	

For trouble-free operation of the electron beam evaporator it is absolutely essential that it is cleaned and serviced at regular intervals.



		NOTICE
	<p><i>The shutdown procedure may only be initiated by skilled personnel according to the definition in DIN EN 60 204 (see also chap. 3.3).</i></p>	

7.1 Complete Daily Cleaning

		DANGER
	<p><i>The shutdown procedure must be followed before any cleaning, maintenance or repair work is carried out (see chap. 4.5). Do not use sharp objects or tools to clean the machine unless they are explicitly intended for this purpose.</i></p>	

7.1.1 Maintenance

In case of the filament power supply the maintenance and cleaning work is only cleaning of the housing when the filament power supply is switched off.

		NOTICE
	<p><i>If there is a need of other maintenance work, please, contact the FERROTEC GmbH Company.</i></p>	

7.1.2 Function test plan

	Interval for One –Shift System				
	W	M	½ Y	Y	MIH
Mains isolator (main switch)				X	
Check all electric terminal and plug connections			X		
Push buttons and switches on the switch cabinet		X			
Check all plug, screw and clamped joints for firmness and tighten if necessary				X	
Function check of the electric drives					X

7.1.3 Inspections

1. Carry out a visual inspection of the switch cabinet.
Check:
 - the wiring for kinks, abrasions and burns,
 - the covers and insulation for damage,
 - the switch cabinet doors for ease of movement.

2. Carry out a function test of all subassemblies in setting mode and in manual mode.

If all the functions work properly, the **machine is handed over** to the operating personnel.

8 Troubleshooting

		DANGER
	<p> The situations and information on faults, their causes and correction in this chapter are described in such a way that they can be understood by skilled persons (see definition chapter. 3.3 „Safety Precautions“)with training in </p> <ul style="list-style-type: none"> - electrical engineering/electronics - mechanical engineering/maintenance. <p>.</p> <p> These technicians must be equipped with the proper tools and test materials. </p> <p> The shutdown procedure (see chap. Fehler! Verweisquelle konnte nicht gefunden werden.) must be carried out before all maintenance and repair work. </p> <p> If the measures described below do not prove successful, please contact FERROTEC GmbH. </p>	

Fault	Cause	Remedy
Power supply cannot be switched ON	Disconnected mains plug The high-voltage connector is not connected and locked Safety conditions are no met Control cable not connected correct	Connect the mains plug Plug Connect and lock the high-voltage connector Ccheck safety interlock circuit Connect control cable correct

9 Emergency

In the event of an emergency:

1. Press the emergency stop button on the master control unit.
The emergency stop button is released by pulling out or turning anticlockwise/clockwise.
2. Switch off the main switch if necessary.

10 Dismantling/Disposal

Dismantling

Dismantling may only be performed by skilled personnel.
Make sure the shutdown procedure is followed before beginning dismantling work.

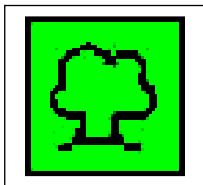

Disposal

The machine is primarily made of copper (except for the electrical equipment) and must be disposed of in accordance with local environmental protection regulations

Oil and cleaning materials must be disposed of in accordance with the local laws and the instructions given in the material safety data sheets

Contaminated cleaning tools (brushes, cloths, etc.) must also be disposed of in accordance with the manufacturer's instructions.