

Electron beam evaporation source / Elektronenstrahl-Verdampfungsquelle ESQ 113 BB 800 059 E/1
 BB 800 059 E/2

Order No. Bestell-Nr.	Quantity Stückzahl	Description Teil	Item Pos.	S / Reference S / Bemerkungen
BK 204 841 -X	1	GRUNDPLATTE KPL. <i>Base plate</i>	1	
BK 204 749 -R	1	FLANSCH <i>Flange</i>	2	
BK 202 685 -T	1	SPULE KPL. <i>Coil</i>	3	
BK 204 861 -T	1	TIEGELABDECKUNG <i>Cover</i>	4	
BK 204 129 -T	1	KATHODE KPL. <i>Cathode</i>	5	BB 800 059 E/3+4 1)
BK 204 126 -T	1	ANODE KPL. <i>Anode</i>	6	BB 800 059 E/5 1)
BK 204 851 -T	1	HALTER KPL <i>Holder</i>	12	BB 800 059 E/6 1)
BK 204 859 -T	1	4-LOCH-TIGEL 4 x 30 CCM <i>Crucible</i>	14	
BK 202 656	1	GEHÄUSE <i>Housing</i>	20	
BK 202 657	1	RING	21	
BK 202 658 -X	1	FLANSCH <i>Flange</i>	22	
BK 202 659	1	HUELSE <i>Bushing</i>	23	
BK 202 660	1	MUTTER <i>Nut</i>	24	
BK 202 661	1	FLANSCH <i>Flange</i>	25	
BK 202 662	1	FLANSCH <i>Flange</i>	26	
BK 202 666	1	FEDERRING <i>Spring ring</i>	27	
BK 202 675	1	HUELSE <i>Bushing</i>	28	
BK 203 115 -U	1	RAENDELMUTTER M10 KPL. <i>Nut</i>	29	
BK 202 678	1	RONDELLE <i>Washer</i>	30	
BK 204 347 -R	1	POLSCHUH RECHTS BK654039 <i>Pole shoe right</i>	31	
BK 204 348 -R	1	POLSCHUH LINKS BK654039 <i>Pole shoe left</i>	32	
BK 204 846	1	RUECKPLATTE <i>Back plate</i>	33	
BK 204 849	1	ABDECKPLATTE <i>Cover plate</i>	35	
BK 202 739	1	WINKEL <i>Angle</i>	36	
BK 202 740	1	SEITENBLECH <i>Side panel</i>	37	
BP 220 380	1	RING	38	
BN 790 249	1	6KT-MUTTER M30X1,5 <i>Nut</i>	39	
BK 202 733	4	Z-SR I-6KT <i>Screw</i>	40	
Spare parts for / Ersatzteile zu				
Electron beam evaporation source / Elektronenstrahlverdampfungsquelle ESQ 113				BB 800 059 E/2 $\frac{2}{1}$
BB 800 059 E/1				

1) SPARE PARTS LIST

Order No. Bestell-Nr.	Quantity Stückzahl	Description Teil	Item Pos.	S / Reference S / Bemerkungen
B 4119 532 -K	2	DICHTRING, CU, SO 7- G 1/4 <i>Seal</i>	45	
B 4101 537 MN	2	E-NI, MS N, SO 1100-10-M14X1,5Z <i>Nipple</i>	46	
B 4133 405 GN	2	EINSTELLWI, MS VNI, SO 2600-10 <i>Angle</i>	47	
RN 809 552 D	2	SCHLAUCHTUELLE <i>Hose nipple</i>	48	
B 4119 367 -M	4	KLEMMRING, MS, SO 1-10 <i>Clamping ring</i>	49	
B 4117 569 GN	4	A-MU, MS-N, SO 20-10-G 3/8 <i>Nut</i>	50	
B 4070 468 PN	1	O-RING, NE, 27 X 4	53	
B 4070 501 PN	1	O-RING, NE, 29,2 X 3	54	
B 4070 644 PV	1	O-RING, VI, 40 X 4	55	
B 4070 675 PV	1	O-RING, VI, 42 X 4	56	
B 4071 092 PV	1	O-RING, VI, 80 X 4	58	
B 4079 155 P	2	HUTM. P, H 14- 4, 14/ 24X 7 <i>Shaft seal</i>	61	
B 4079 309 VN	1	HUTM. VI, 25/38X6,5 *BNR15029* <i>Shaft seal</i>	62	
N 4001 318	1	RIL-K-LAGER 6001, 12/ 28X 8 <i>Ball bearing</i>	65	
N 3052 189 X	4	Z-SR, INOX, M 3 X 6 <i>Screw</i>	67	
N 3052 203 X	2	Z-SR, INOX, M 3 X 25 <i>Screw</i>	69	
N 3059 259 X	8	Z-SR I-6KT, INOX, M 4 X 16 <i>Screw</i>	72	
N 3015 298 X	3	6KT-SR, INOX, M 5 X 20 <i>Screw</i>	73	
N 3059 296 X	4	Z-SR I-6KT, INOX, M 5 X 16 <i>Screw</i>	74	
N 3059 293 8P	4	Z-SR I-6KT, 8.8 VZNP, M 5 X 20 <i>Screw</i>	75	
N 3111 191 X	2	S-SR 90, INOX, M 3 X 8 <i>Screw</i>	79	
N 3211 251 X	1	GEW-STI I-6KT ZA; INOX; M 4 X 9 <i>Threaded pin</i>	82	
N 3208 298 X	2	GEW-STI I-6KT K; INOX; M 5 X 20 <i>Threaded pin</i>	83	
N 3477 120 X	2	RAENDEL-MU HOCH, INOX, M 5 <i>Nut</i>	88	
N 3502 412 X	6	U-SR, INOX, 3,2/ 7 X 0,5 <i>Washer</i>	91	
N 3502 414 X	12	U-SR, INOX, 4,3/ 9 X 0,8 <i>Washer</i>	92	
N 3502 416 X	9	U-SR, INOX, 5,3/10 X 1 <i>Washer</i>	93	
N 3502 416 4P	4	U-SR, 4 VZNP, 5,3/10 X 1 <i>Washer</i>	94	

Spare parts for / Ersatzteile zu

Electron beam evaporation source / Elektronenstrahlverdampfungsquelle ESQ 113

BB 800 059 E/2 $\frac{2}{2}$

BB 800 059 E/1

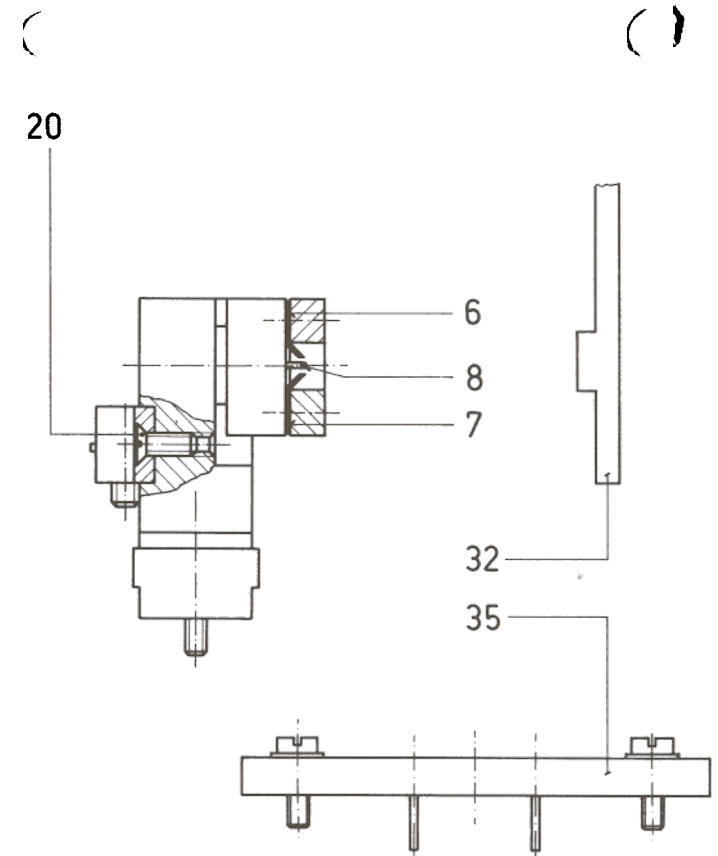
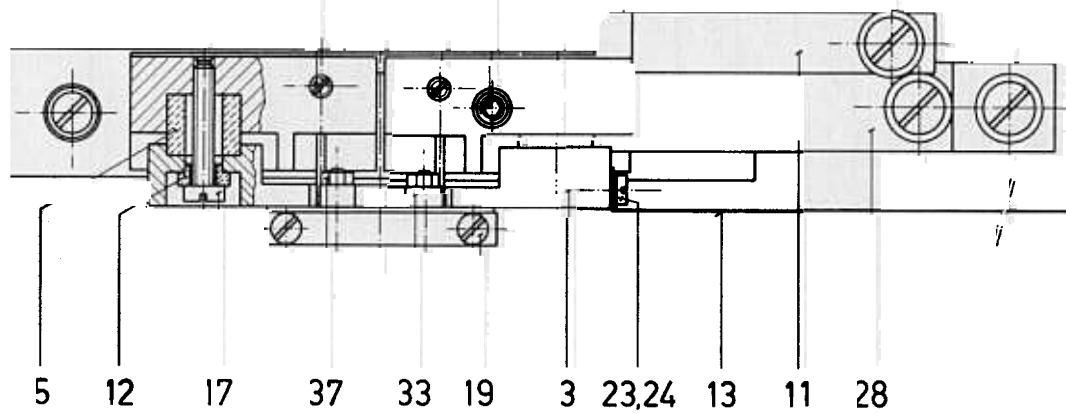
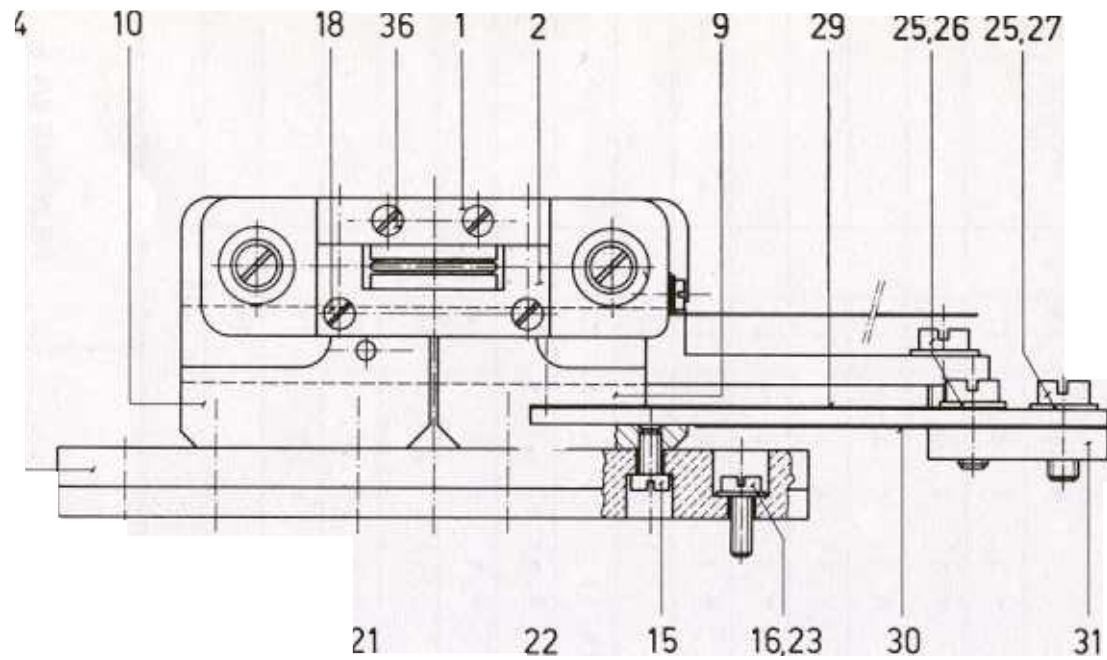

BB 800 059 E/4

Cathode / Kathode

BB 800 059 E/3

Order No. Bestell-Nr.	Quantity Stückzahl	Description Teil	Item Pos.	S / Reference S / Bemerkungen
BK 204 737	1	BALKEN <i>Balk</i>	1	
BK 202 698	1	JOCH <i>Yoke</i>	2	
BK 202 699	1	WEHNELTTRAEGER <i>Wehnelt holder</i>	3	
BK 202 700	1	ISOLATOR <i>Insulator</i>	4	
BK 202 701	2	ISOLATOR <i>Insulator</i>	5	
BK 202 702	1	WEHNELTBLECH <i>Wehnelt panel</i>	6	
BK 202 703	1	WEHNELTBLECH <i>Wehnelt panel</i>	7	
BK 202 704 -R	1	KATHODE <i>Cathode</i>	8	BK 604 018 A
BK 202 718	1	KATHODENHALTER <i>Cathode holder</i>	9	
BK 202 719	1	KATHODENHALTER <i>Cathode holder</i>	10	
BK 202 745	1	ANSCHLUSSCHIENE <i>Connection bar</i>	11	
B 4622 251 TN	2	EINZELTUELLE <i>Sleeve</i>	12	71-6115
B 2220 140 -W	1	DRAHT, NI 99,8, <i>Wire</i>	13	Ø 1 500.00 MM
N 3052 189 X	4	Z-SR, INOX, <i>Screw</i>	15	M 3 X 6
N 3052 193 X	2	Z-SR, INOX, <i>Screw</i>	16	M 3 X 10
N 3052 198 X	2	Z-SR, INOX, <i>Screw</i>	17	M 3 X 16
N 3111 114 X	2	S-SR 90, INOX, <i>Screw</i>	18	M 2 X 6
N 3111 116 X	2	S-SR 90, INOX, <i>Screw</i>	19	M 2 X 8
N 3111 191 X	2	S-SR 90, INOX, <i>Screw</i>	20	M 3 X 8
N 3204 188 X	2	GEW-STI ZA; INOX, <i>Threaded pin</i>	21	M 3 X 5
N 3208 251 X	1	GEW-STI I-6KT K; INOX; <i>Threaded pin</i>	22	M 4 X 8
N 3502 412 X	3	U-SB, INOX, <i>Washer</i>	23	3,2/ 7 X 0,5
N 3052 186 X	1	Z-SR, INOX, <i>Screw</i>	24	M 3 X 4
N 3502 414 X	3	U-SB, INOX, <i>Washer</i>	25	4,3/ 9 X 0,8
N 3052 251 X	2	Z-SR, INOX, <i>Screw</i>	26	M 4 X 8
N 3052 253 X	1	Z-SR, INOX, <i>Screw</i>	27	M 4 X 10
BK 203 010	1	ANSCHLUSSCHIENE <i>Connection bar</i>	28	
BK 203 011	1	LEITBLECH <i>Deflector</i>	29	

Spare parts for / Ersatzteile zu

Cathode / Kathode

BB 800 059 E/4 $\frac{2}{1}$

BB 800 059 E/3

Order No. Bestell-Nr.	Quantity Stückzahl	Description Teil	Item Pos.	S / Reference S / Bemerkungen
BK 203 012	1	LEITBLECH <i>Deflector</i>	30	
BK 203 013	1	VERSTEIFUNG <i>Stiffening</i>	31	
BK 203 014	1	EINSTELLEHRE <i>Feeler gauge</i>	32	
BK 202 735	2	DISTANZHUELSE <i>Sleeve</i>	33	
BK 204 739 U	1	JUSTIERBALKEN KPL. <i>Adjustment balk</i>	35	
N 3111 118 X	2	S-SR 90, INOX, M 2 X 10 <i>Screw</i>	36	
N 3415 027 X	2	6KT-MU 0,80, INOX, M 2 <i>Nut</i>	37	
BK 202 720 EZ		KATHODE KPL.		
BK 204 740		MONTAGEHINWEIS		BEILEGEN
BK 850 197 -V	1	MONTAGEVORSCHRIFT		BEILEGEN

Spare parts for / Ersatzteile zu

Cathode / Kathode

BB 800 059 E/4 ²/₂

BB 800 059 E/3

Order No. Bestell-Nr.	Quantity Stückzahl	Description Teil	Item Pos.	S / Reference S / Bemerkungen
BK 202 722 -X	1	ANSCHLUSSWINKFL. GEFLOETET <i>Angle</i>	1	
BK 202 688	1	ANODE 1	2	
BK 202 689	1	ANODE 2	3	
BK 202 723	1	ANODENHALTER <i>Holder</i>	4	
B 4622 251 TN	2	EINZELTUELLE 71-6115 <i>Sleeve</i>	6	
N 3052 191 X	2	Z-SR, INOX, M 3 X 8 <i>Screw</i>	8	
N 3111 191 X	8	S-SR 90, INOX, M 3 X 8 <i>Screw</i>	10	
N 3111 194 X	1	S-SR 90, INOX, M 3 X 12 <i>Screw</i>	11	
N 3111 267 X	2	S-SR 90, INOX, M 4 X 30 <i>Screw</i>	12	
N 3415 037 X	1	6KT-MU 0,80, INOX, M 3 <i>Nut</i>	14	
N 3502 412 X	3	U-SB, INOX, 3,2 / 7 X 0,5 <i>Washer</i>	16	
BK 202 724 AZ		ANODE KPL.		

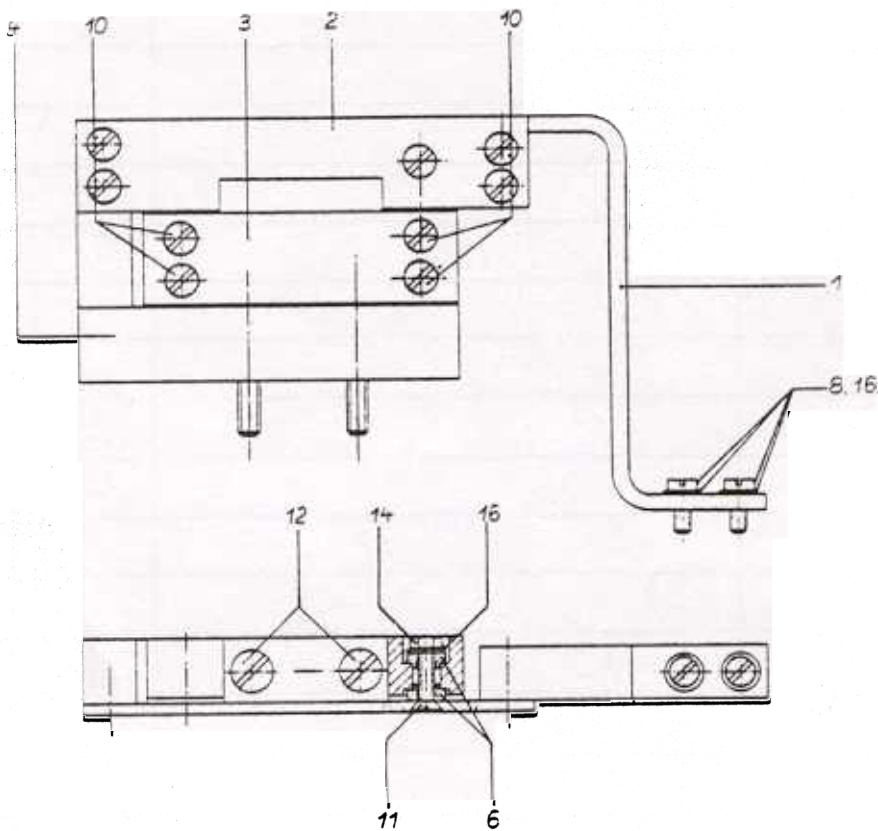

Spare parts for / Ersatzteile zu

Anode

BB 800 059 E/5

Order No. Bestell-Nr.	Quantity Stückzahl	Description Teil	Item Pos.	S / Reference S / Bemerkungen
BK 204 853 -X	1	HALTER <i>Holder</i>	1	
BK 204 855	1	WASSERFUEHRUNG <i>Water-guide</i>	2	
BB 178 473	4	ROHR <i>Pipe</i>	3	
BK 204 857 -R	1	TOPF <i>Pot</i>	4	BR603159
BK 202 674	1	KEIL <i>Key</i>	5	
N 3052 191 X	8	Z-SR, INOX, <i>Screw</i>	6	M 3 X 8
N 3570 018 X	1	SCHW-SP-STI, INOX, <i>Pin</i>	7	S 1 X 5
B 4071 376 PV	1	O-RING, VI, AN 250, 126,6 X 3,53	8	
BK 204 850 -Z		HALTER KPL <i>Holder</i>	20	

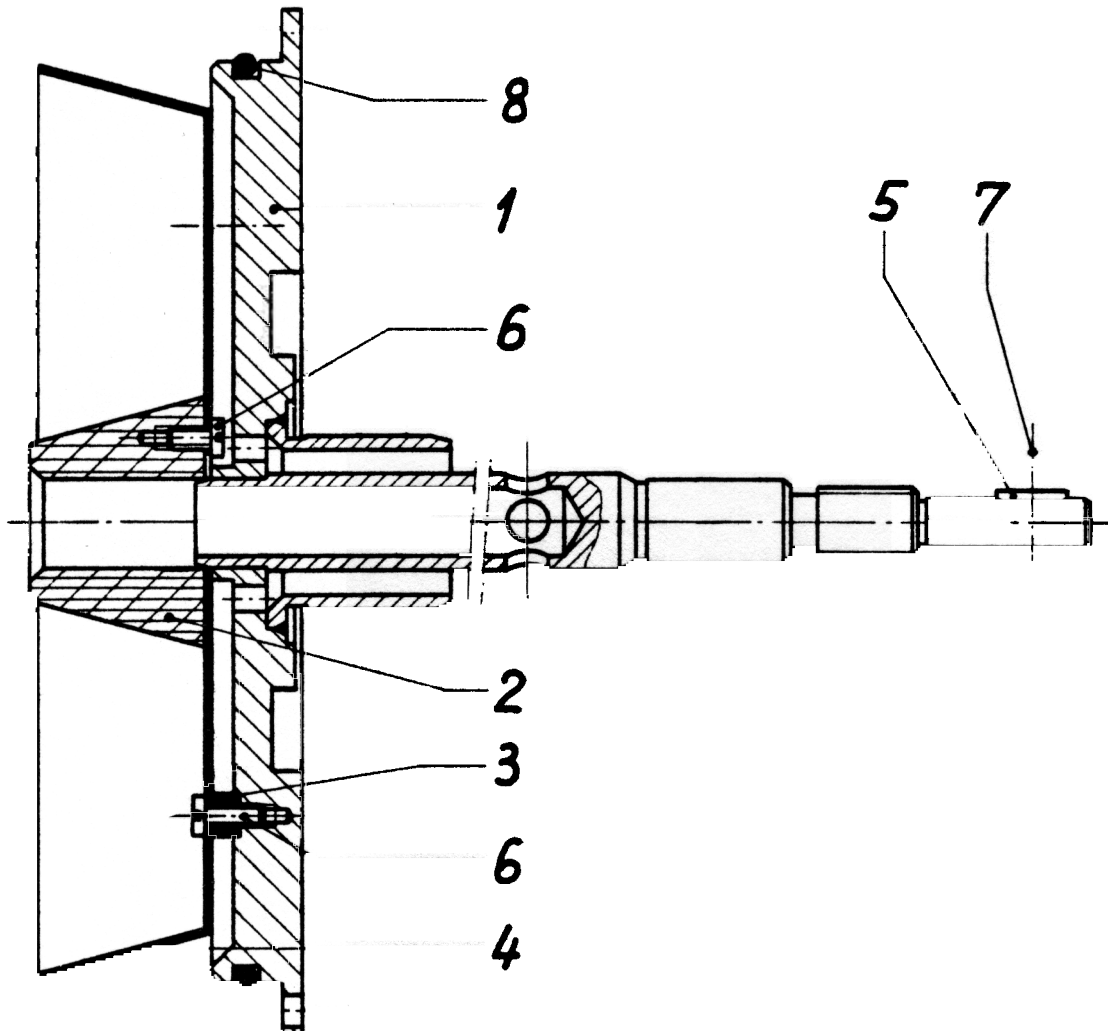

Spare parts for / Ersatzteile zu	BK 204 851 -T	
Halter		BB 800 059 E/6