

Wordentec WAVE System Upgrades

Cost effective, low risk upgrade route for coating systems. Maximise the value of existing plant while updating vulnerable or obsolete instrumentation.

Modern 'industry standard' controls and proven Ferrotec electron beam evaporators provide performance with reliability.

Key Features

- Industry Standard Deposition Control
- PC Based WAVE Control Software
- Pneumatic Controls Replaced
- Fully Monitored and Interlocked Safety Control
- Active Vacuum Gauges
- Industrial Windows PC
- Alarm Monitoring Remote support
- Multi-Channel Water Distribution With Ultrasonic flow Sensors



Improved Up Time and Reduced Maintenance Costs

Unreliable and obsolete items are renewed or replaced. This increases the lifetime of the system, improves reliability, repeatability and productivity. These aspects combine to help keep the machine on line whilst keeping unwanted costs of maintenance low by using good quality and 'off the shelf' parts.

Fast Track To Production

One of the key benefits of upgrading an existing system is that the chamber geometry is unchanged. Processes that are already being used in production can be re-created in the new controls and validated a lot faster as there is little change to the uniformity and material dispersion data

Efficient Install Within 1 Week

For any upgrade we pre-build the control rack at our facility and assemble all the components required before the install. Due to the wealth of experience from our team, whether it is an on-site upgrade or one we have done at our facility we can usually install the system within 1 week.

Wordentec WAVE 760 System Upgrade Overview

Original Vacuum System

Parts we replace or upgrade include: control racks, control instruments, terminal box, rotary drive motor, chamber components, water panel.

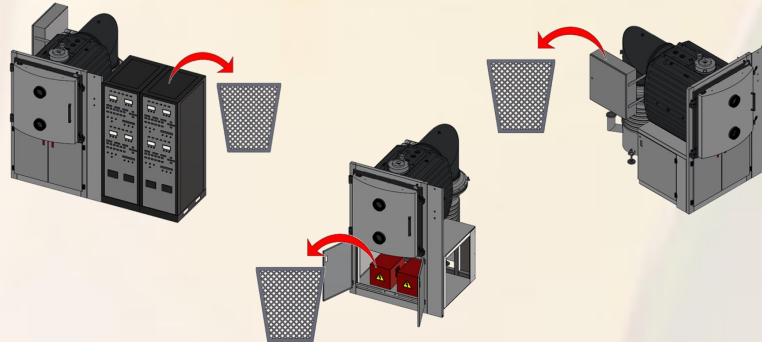

Wordentec WAVE Control Software

WAVE – Wordentec Advanced Vacuum Environment

- Material data (films) and processes (combinations of films) can be created, stored and edited.
- WAVE enables password protected levels of operation.
- All the hardware and software platforms employed are standard industrial products with application specific customisation.

WAVE fully integrates the control, monitoring and automation of:

- Vacuum Gauges
- Shutters
- Vacuum Pumps
- Evaporation sources
- Sputter Sources
- Plasma/ Ion Source
- Heaters
- Rotation

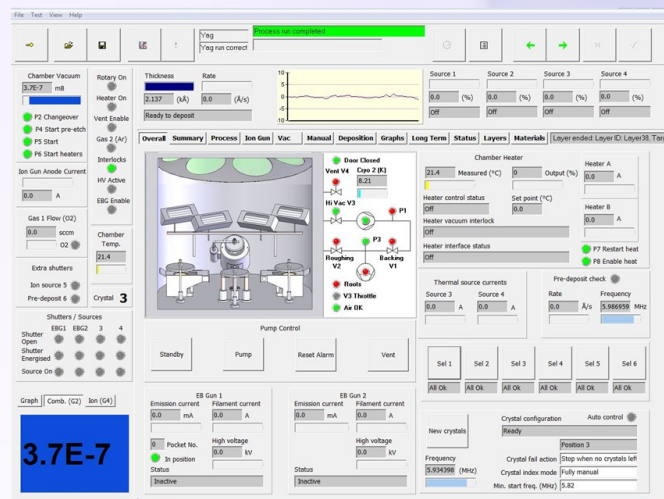

New Integrated Control Rack

We pre-build and integrate a new control rack customised with the instruments required for a specific upgrade.

Standard components used in a control rack include:

- Ferrotec Genius EB Gun Controller(s)
- Ferrotec Carrera Power supply
- Touch Screen HMI
- Industrial Windows PC

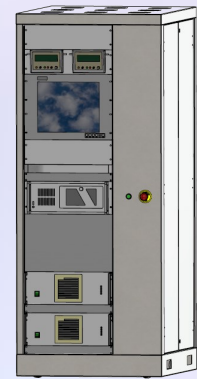

All New Power Distribution and Control Panel

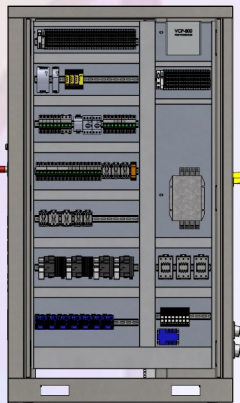

We create a new power distribution and control panel for all upgrade systems which includes the highest standards components and features such as:

- Beckhoff Industrial Fieldbus I.O.
- Approved Safety Interlocks and Emergency Stop
- Eurotherm Power Controllers
- VCP Pump Station Controller
- Circuit Protection devices

Refurbished and Serviced Parts

When we carry out an upgrade, any parts that are not replaced are fully refurbished, serviced and tested so you can be assured of great reliability from the new system.

The main parts that get refurbished and serviced include:

- Chamber and Framework
- High Vacuum Pump
- Roughing and Roots Pumps
- Vacuum Valves
- Rotary Drive
- Quartz Crystal Sensor

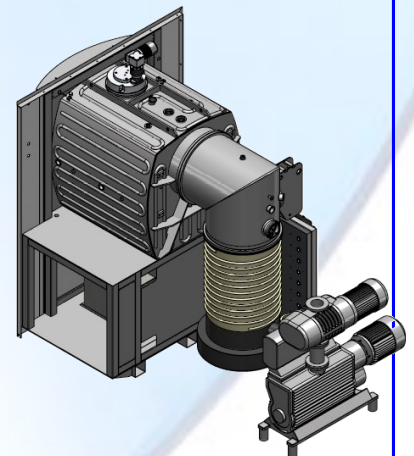

About Wordentec

Wordentec are a global supplier of instruments and systems to the high vacuum and thin film coatings industry. Using the company's extensive vacuum engineering experience, Wordentec are able to provide innovative solutions to vacuum engineering challenges. The company has a growing range of new products including instruments and accessories for thin film coating. The company continues to provide system refurbishment and reconfiguration services that offer a very economic alternative to new equipment.

Wordentec provides application specific knowledge and expertise to create custom made equipment with flexibility to help you realise the full potential of vacuum coating.



Wordentec Ltd
Lake Industrial Estate
Shebbear
Devon
EX21 5SP
Tel: +44 (0)1409 281853
Email: info@wordentec.com